

GeoBox

G408 Video Wall Controller User Guide

8 channel 4k/60 Video Wall controller

Support up to 4k2k @60Hz or 7680x1200 @30 Hz input

2x HDMI 2.0b in, 8x HDMI 1.4 out, 10-bit processor 4:4:4

Chroma sampling

Independent rotation/ scaling/ cropping Act as

two Quad channel Processors



Sales & Technical support

Web site: www.VigilLink.com

E-mail: info@vigillink.com Version: VL-V1.01

Tel: +949-502-4484

DCi/UHD 4k/60/4:4:4	HDMI 2.0	HDCP 2.2/1.4	10-bit High-end scaler	Cadence Film 3:2 / 2:2	3D Motion De-interlace	Deep Color xvYCC/12-bit	
Mosaic Irregular wall	Multi-Unit Cascade	Flexible Aspect Ratio Bezel Correction	Rotation Landscape Portrait	Loop Out Daisy chain	Control IR/USB/RS232 /Ethernet	Projector Output overlap	RoHS CE FCC

Table of Contents

Disclaimer/Copyright statement.....	1
Warranty/RMA and FCC/CE statement.....	2
Introduction.....	3
Feature.....	3
Quick Setup Guide	
1. Content in the packing box.....	4
2. Quick setup via IR Remote Controller	4
System Setup procedures	
1. System structure.....	6
2. Connecting the inputs.....	6
3. Connecting the Outputs.....	7
4. HDMI Loop Out for Multiple Units Connection and Monitoring.....	9
5. System Connection and Power On.....	10
6. Input Source / Output Resolution Selection & LED Indicators.....	10
7. Set 10-bit color output	12
8. System setting: Box ID, RS232, Ethernet	12
9. Video Wall Settings.....	14
9.1. [Zoom] – Split Source Image.....	14
9.2. [Pan] – Assign Image Position.....	15
9.3. [Overlap] – Bezel Compensation and Position Alignment.....	15
9.4. 3x3 Video Wall Setup.....	16
9.5. Bezel Compensation.....	17
10. OSD Lock and Unlock.....	17
11. Save and Load system settings.....	18
12. System Reset	19
13. Irregular / Asymmetric video wall setting	
13.1. Introduction.....	19
13.2. Wind-Mill Asymmetric Video Wall Setup Procedures.....	20
13.3. Square Asymmetric Video Wall Setup Procedures.....	24
13.4. Aspect ratio and image distortion	26
13.5. Other big-scale asymmetric video walls.....	27
14. Flexible Aspect Ratio Adjustment.....	31
15. PC Tool.....	32
15.1. WebGui.....	33
15.2. UHDWall Manager (UWM) PC Tool.....	34
16. System structure and operation behavior.....	35

17. Miscellaneous features

- 17.1. EDID Setting 36
- 17.2. HDMI vs. DVI Output Signal..... 36
- 17.3. System Standby and Automatically Turn Off Output Signal. 37
- 17.4. Change Background Color..... 37
- 17.5. Change OSD menu display time..... 37
- 17.6. Change splash screen logo display time..... 37

18. Helpful tips for video wall settings..... 37

19. Limitations in Image Flip and Rotation..... 38

Technical Support

- 20. Trouble Shooting..... 38
- 21. Technical Support..... 40
- 22. Safety Precaution and Maintenance..... 40

Specifications..... 42

Revision history 43

Disclaimer/Copyright Statement

Copyright 2022, VNS Inc.. All Right Reserved

This information contained in this document is protected by copyright. VNS Inc. reserves all rights. VNS Inc.. Reserves the right to modify this document without any obligation to notify any person or entity of such revision. Copying, duplicating, selling, or otherwise distributing any part of this document without signing a non-disclosure agreement with an authorized representative of VNS Inc.. is prohibited. VNS Inc.. Makes no warranty for the use of its products and bears no responsibility for any error or omission that may appear in this document. Product names mentioned herein are used for identification purposes only and may be trademarks of their respective companies.

Limited Warranty and RMA statement

This device is designed and tested to the highest standards and backed by thirty-months parts and labor warranty. Warranties are effective upon the first delivery date to the end customer and are non-transferable. Warranty-related repairs include parts and labor but do not include repair of faults resulting from user negligence, special modifications, abuse (mechanical damage), shipping damage, and/or other unusual damages. The customer shall pay shipping charges when the unit is returned for repair. Manufacturers will pay shipping charges for return shipments to customers.

The manufacturer does not assume responsibility for consequential damages, expenses or loss of revenue, inconvenience or interruption in operation experienced by the customer. Warranty service shall not automatically extend the warranty period.

Please contact us for more details. In the event that a product needs to be returned for repair, inform the manufacturer and ask for a Return Material Authorization number.

FCC/CE statement

This equipment has been tested and found to comply with the limits for a Class A digital device, pursuant to part 15 of the FCC Rules. These limits are designed to provide reasonable protection against harmful interference when the equipment is operated in a residential/commercial environment. This equipment generates, uses, and can radiate radio frequency energy and, if not installed and used in accordance with the instruction manual, may cause harmful interference to radio communications. Operation of this equipment in a residential area is likely to cause harmful interference in which case the user will be required to correct the interference at his own expense.

Introduction

GeoBox G408 is 8 channel 4k2k/60 fps Video Wall controller. It is designed with two processing modules. Each processing module consists of 1x HDMI 2.0b input, 1x HDMI 2.0b loop-out port for daisy chain connection, and 4 synchronized HDMI 1.4 outputs. It can serve as one eight-channel video wall controller or two quad-channel video wall controllers. Each output has independent image rotation/flip, scaling, split, cropping, and color adjustment to allow great freedom in creating video walls with variable display scales and styles.

It is pure hardware, a standalone system, and ease of use. All operations can be executed through IR remote controller, USB, RS232, or Ethernet. No additional PC or appropriate software is required in the setup.

Features

- ✧ Two processing modules, each module consists of below I/O ports.
1x HDMI2.0b input, 4x HDMI1.4 output up to 2048x1200 @60Hz with flexible multi-unit cascade.
- ✧ It can serve as two Quad-channel processors or one 8-channel processor while the user connects two processing modules through the loop-out port.
- ✧ Support up to 4096x2160@60Hz, 7680x1200 @30Hz input.
- ✧ Input supports HDCP 1.4/2.2, and output supports HDCP 1.4.
- ✧ Two Loop-through ports for multiple unit cascade in any scale display.
- ✧ Pixel base position alignment up to +_ 1800 pixels in H&V for flexible image capture, cropping, position alignment, bezel compensation & irregular video wall.
- ✧ Set overlap output up to 1800 pixels for projector edge blending application.
- ✧ Independent Image color adjustment in each channel.
- ✧ Independent image rotation and flip/mirror in each channel for variable landscape, portrait, and irregular video wall display.
- ✧ The selectable output resolution and programmable EDID optimize video quality.
- ✧ Flexible aspect ratio adjustment in each edge up to +_ 1800 pixels.
- ✧ Frame rate conversion and 50Hz in / 50Hz out to keep video quality without artifacts.
- ✧ Frame-Lock function to get perfect synchronization among output channels.
- ✧ Easy setup via IR, USB, RS232 & Ethernet. No PC is required.
- ✧ Ready for a 24/7 working environment.

Quick Setup Guide

1. Content in the packing box

- The G408 8-Channel Video Wall Controller
- 1x RC-400 IR Remote Controller with battery
- 1x IR Extending Receiver with 1.8m cable
- 1x AC Main Power Cord.
- 1x DC 12V Power Supply Unit
- Mounting Rack with screw (Option)
- Please download UHD Wall Manager PC Tool at <https://www.geoboxav.com/download-center>.

2. Quick Setup via IR Remote Controller

2.1. How to extend the distance of IR control

- IR remote controller is designed for the operation of G408.
- IR receiver is on Front Panel. One 3.5ø mm audio connector for IR extender is located at Back Panel of G408. 1.8m IR extension cable is equipped in the packing. User can add audio cable to extend the distance up to 20 meters.



2.2. How to avoid IR interference in multiple unit application

- If multiple units are used, user can set different [Box ID] (#1 - #99) or IP address in each Box for individual control. For IR control, the [Box ID] number range is #1 - #9.
- User can control individual GeoBox through below method when all boxes or IR extender receivers are installed together.
 - ✓ Press 851 number key on remote controller will lock all other G408 OSD menu except G408 with Box ID #1. User can see flashing LED on the Front Panel for the units with OSD locked.
 - ✓ Press 853 will only unlock ID # 3 G408 for further OSD operation and lock all the others.
 - ✓ Press 850 will unlock all G408 OSD Menu. Remote controller can control all boxes at the same time.

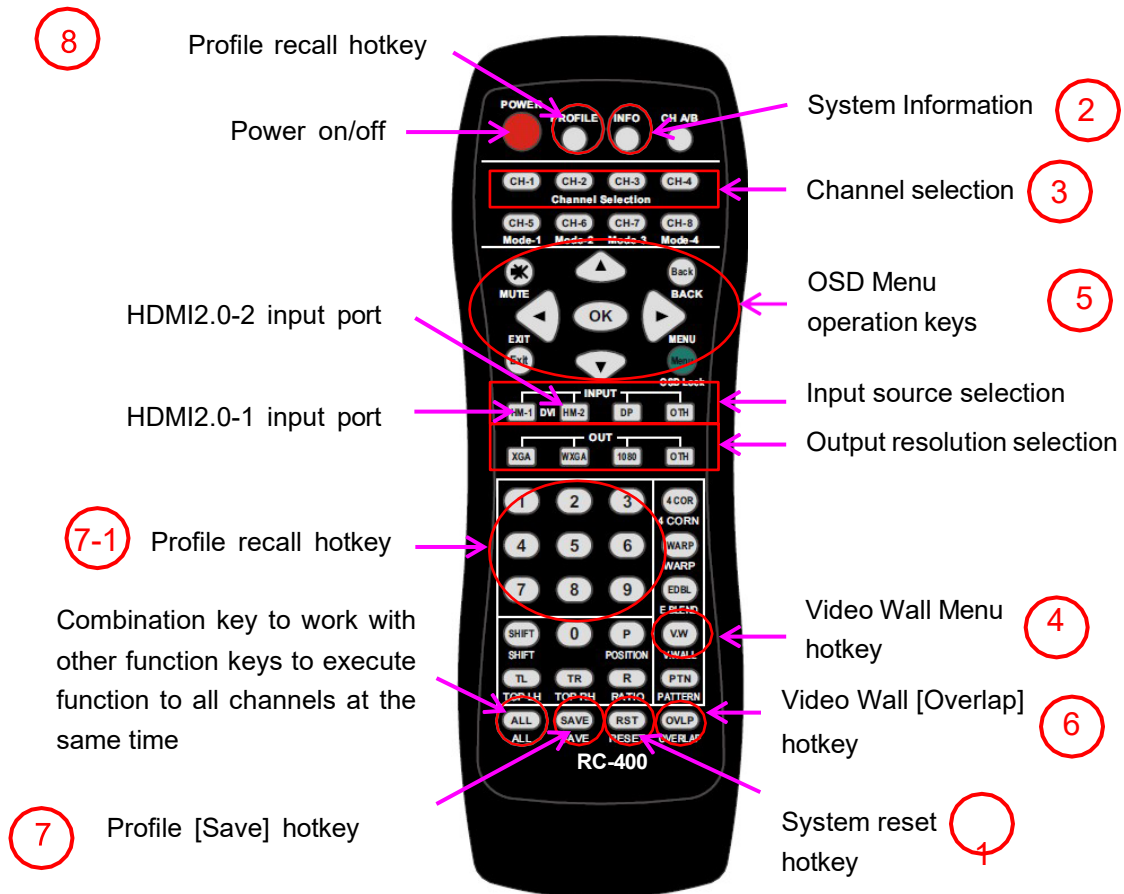

2.3. Quick Video Wall setting through remote controller

- 1) Click [RESET] hotkey to clear unnecessary settings in each Processor (two channels). Each Processors shall be reset separately.
- 2) Click [INFO] key and check input/output timings are correct or not.
- 3) Select Channel 1 to do settings.
- 4) Click [V. Wall] hotkey to open Video Wall OSD menu.
- 5) Use OSD Operation keys to do [Zoom], [Pan] and [Overlap] settings.
- 6) If necessary, use [Overlap] hotkey to adjust image position or aspect ratio.
Please repeat (3) to (6) processes for all channels.
- 7) After finish the settings for all channels, click [Save] hotkey, then click Number key (7-1) to save the final result into [Profile] → [Index]. Only 1-5 is valid for selection. User can save twice to different Indexes as backup.
Click [Reset] (1) hotkey again to reset the system to test if the setting is properly saved or not.
- 8) Click [Profile] hotkey and click Number key (7-1) again to recall the setting and make sure the settings are saved correctly.

System Setup Procedures

1. System structure

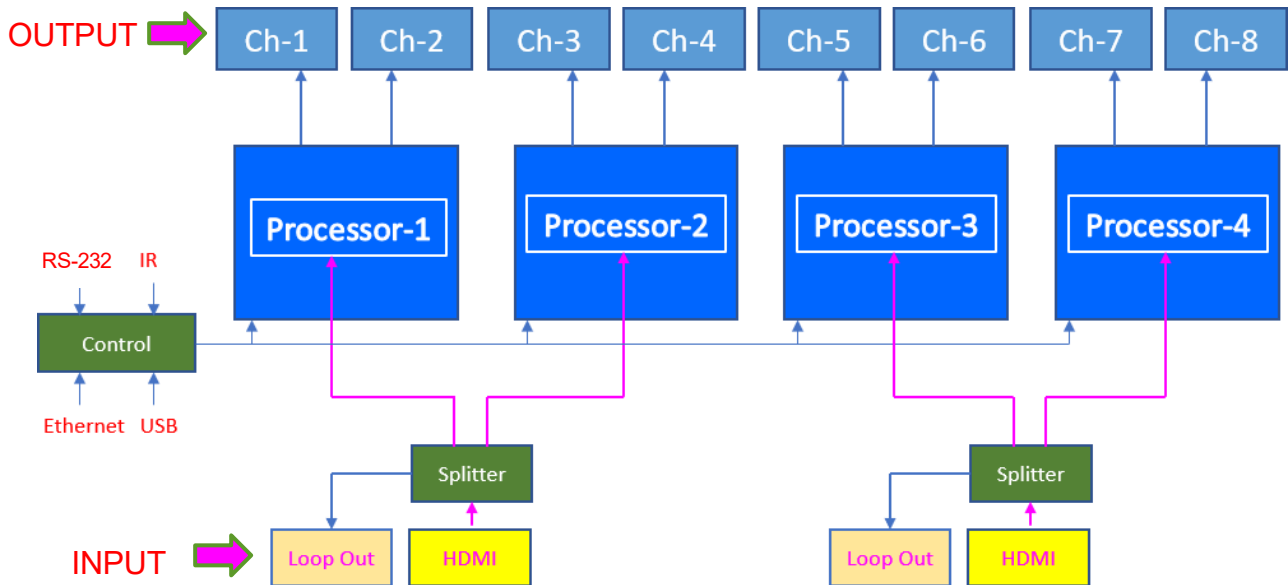

- There are 4 Processors in G408. Each Processor controls two outputs. Processor-1 controls CH-1 / CH-2. Processor-2 controls CH-3 / CH-4. Processor-3 controls CH-5 / CH-6 and Processor-4 controls CH-7 / CH-8.
- The settings for system control are done by Processor-1 (CH-1/CH-2).
- Each processor has independent System Reset and Save.
- Each Processor shares the same OSD menu. User can switch among two output channels in each Processor by [CH A/B] hotkey in remote controller.
- HDMI-A input port will share the input signal for Processor-1 & Processor-2 and Loop out-1.
- HDMI-B input port will share the input signal for Processor-3 & Processor-4 and Loop out-2.
- Each output has independent image rotation/flip, scaling, cropping and color adjustment.

2. Connecting the inputs

- Apply signal source to HDMI input port before video wall settings. Otherwise, the Video wall Overlap setting result may be not correct.
- There are two identical processing modules in G408. Each module includes one HDMI input port, one HDMI Loop out port and 4x HDMI output ports.
- CH 1/2/3/4 output is defined as Module A and CH 5/6/7/8 is Module B.
- HDMI 2.0-A input source is only for Module A and HDMI 2.0-B is only for Module B.
- When user wants to display one content across entire 8 monitor video wall, user needs to connect source signal to Module A and Module B at the same time. Input signal can be connected to HDMI-A (or HDMI-B) then daisy chain to HDMI-B though Loop out connection via HDMI cable.

- User can display two different contents in the system when apply different contents to Module A and Module B.

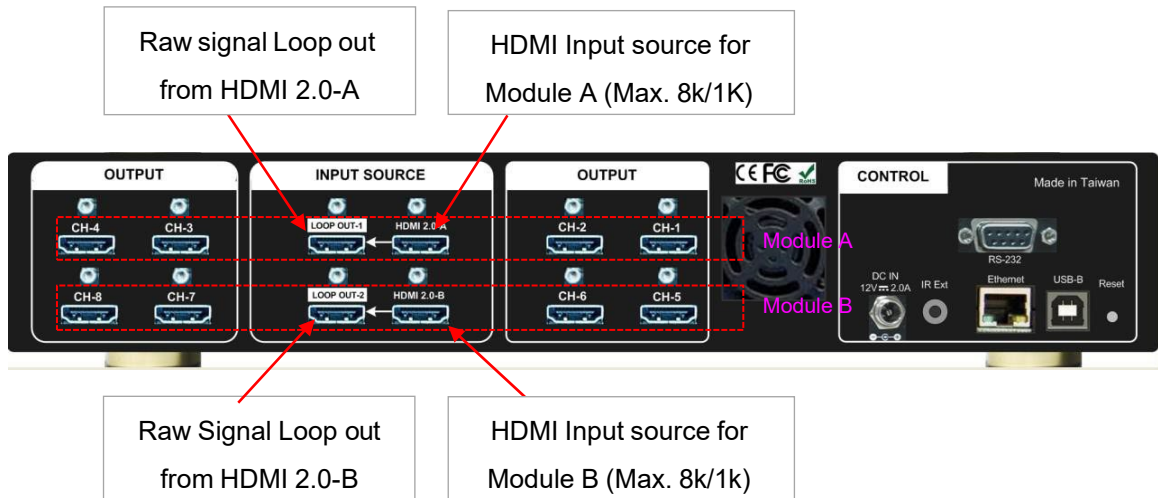

3. Connecting the outputs

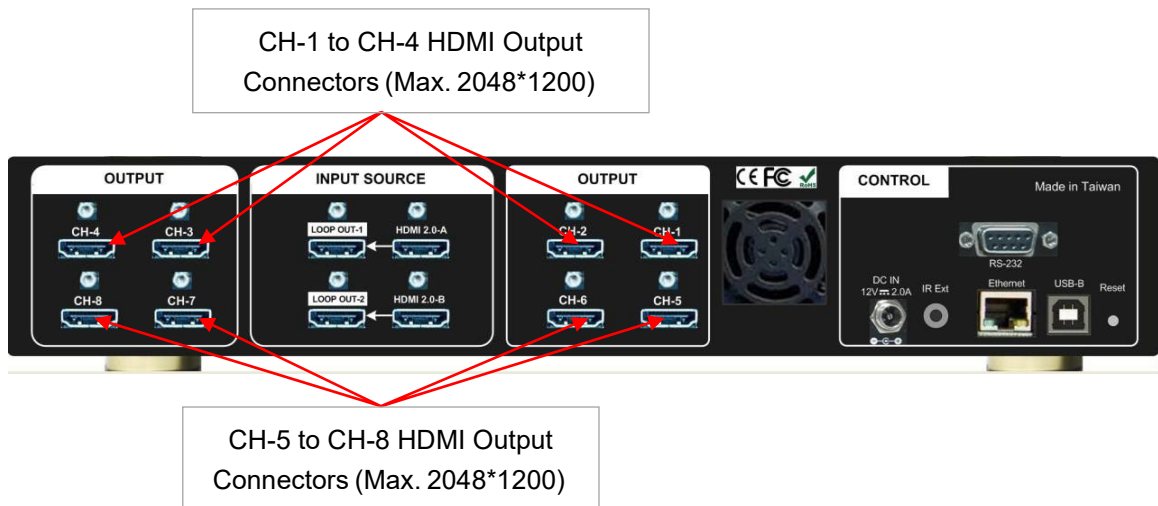

- If user wants to display single content across entire video wall, user can connect any output to any monitor without limitation. User can assign the final image location through Video Wall [PAN] settings.

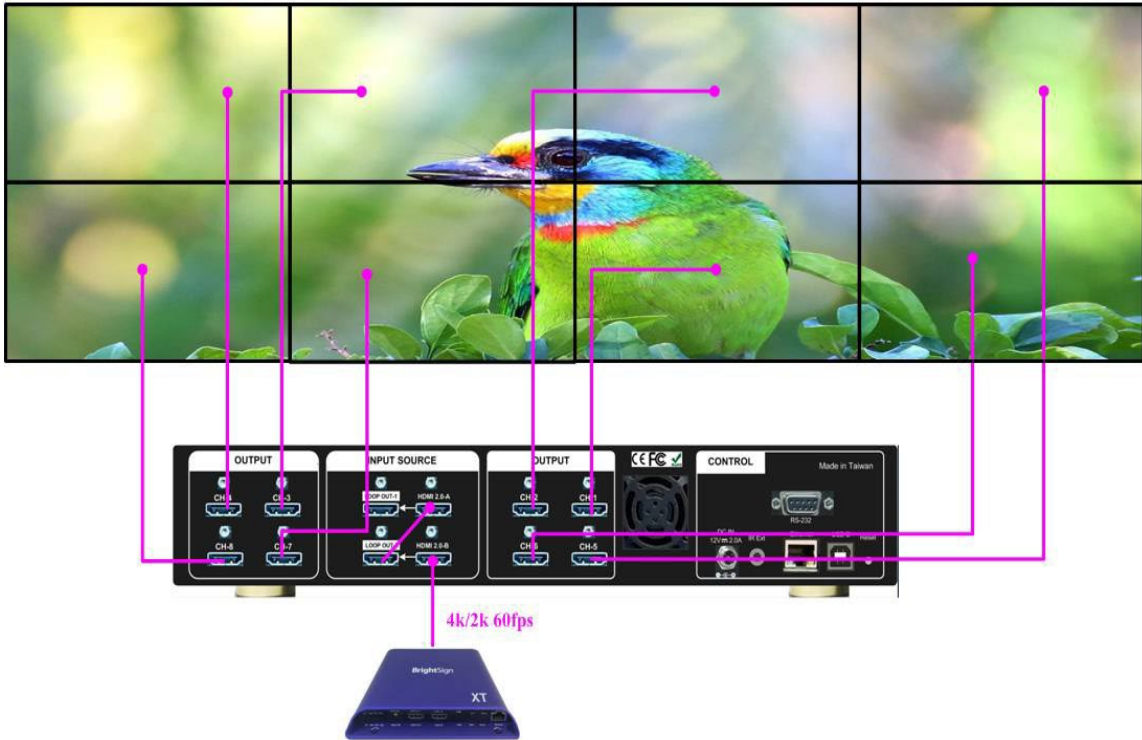

- If user wants to display two different contents across 8 monitors, user needs to connect the outputs in Module A to the monitors to show A content and Module B outputs to the monitors to show B content. There is no special sequence in the connection in each display Module.

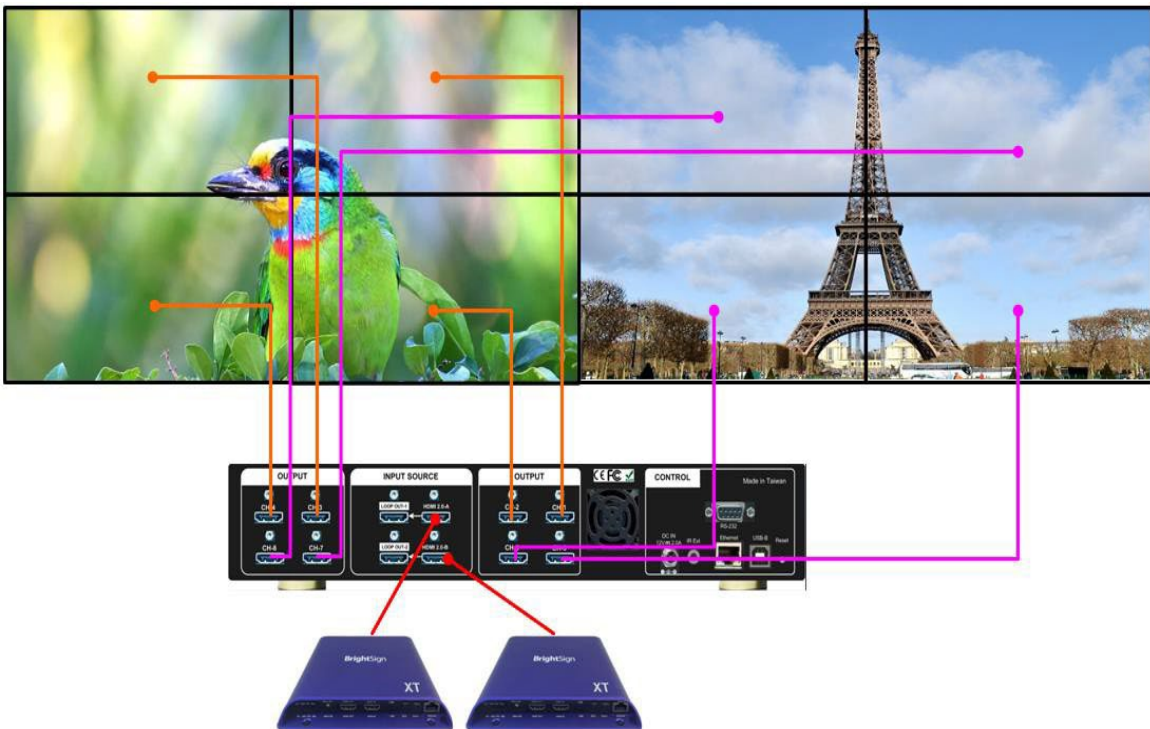

4. HDMI Loop Out for Multiple Unit Connection and monitoring

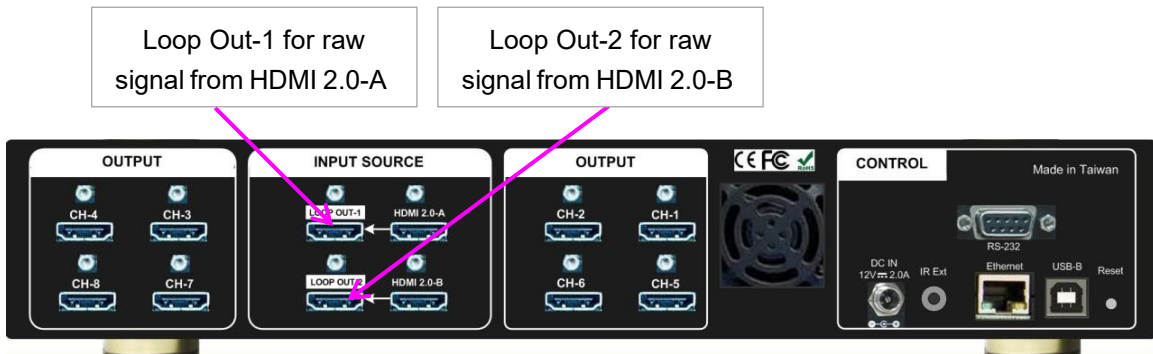

- Loop Out-1 provides the same unprocessed source signal from HDMI2.0-A input port. Loop Out-2 provides the same unprocessed source signal from HDMI2.0-B input port.
- User can connect any Loop Out signal to any HDMI input port in the next processing module or next G408 unit.
- User can connect up to 5 units of G408 through daisy chain connection. The daisy chain connection number is related to source resolution and the quality of HDMI cables—poor cable will have less connection number and good cable can connect more units in daisy chain connection. If more monitor control is necessary, user can add HDMI splitter or use multiple signal sources (display card, PC or synchronized multimedia players) to expand connection without limitation. For instance, user can use 1x4 HDMI splitter at the front end and provide the same signal to 4x G408 daisy chain groups. if each daisy chain group consists of 5 units of G408, the total LCD can be connected will be $4 \times 5 \times 8 = 160$.



- If Loop out port has not been used, user can use loop out port for monitoring system in control room to see the status of the video wall content.

5. System Connection and Power On

- Poor quality HDMI cable and signal source will affect the connection distance and may cause signal noise.
- To ensure all cables are connected correctly, it is recommended to use locking cables.



- Complete video wall system should be connected to one power Distribution Box with proper grounding. Power on the system after finishing all connections to avoid system damage by floating voltage among devices.
- When G408 power is switched on, the booting time is about 19 seconds and the Input & Output LEDs on front panel will stay “Lighted” permanently for the channel with correct input source and output monitor connections after finishing booting process.

6. Input Source / Output Resolution selection & LED Indicators

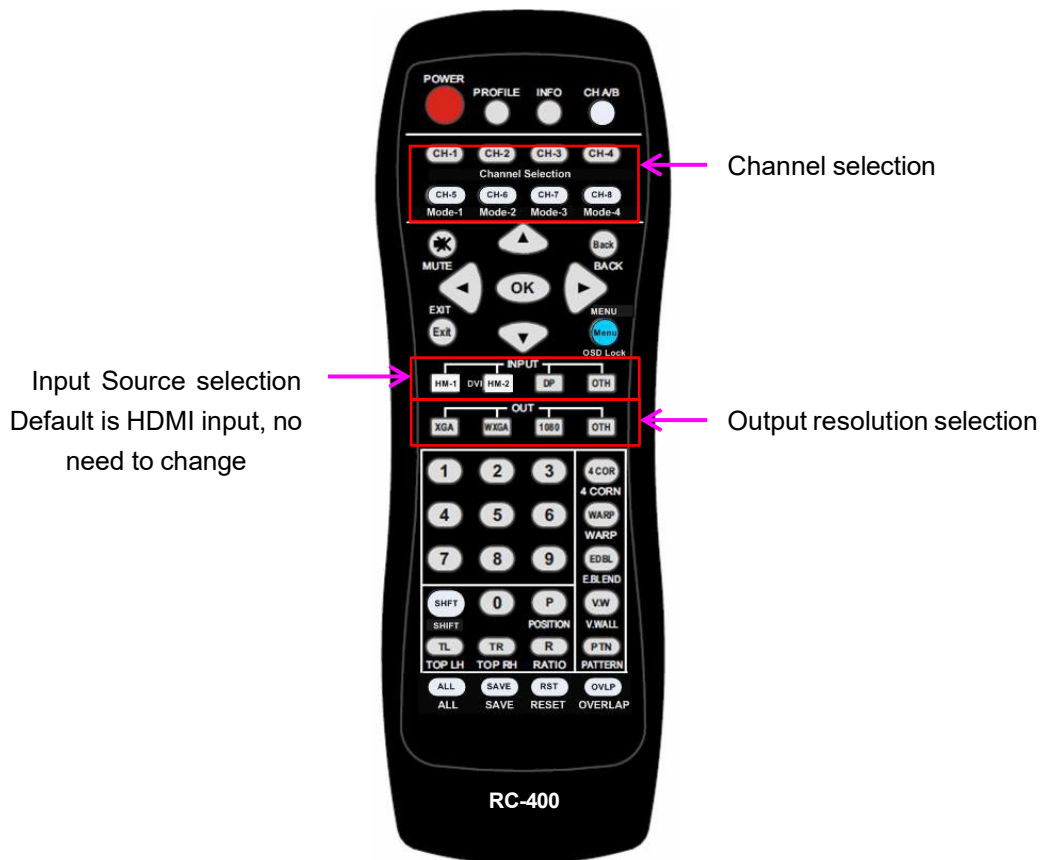

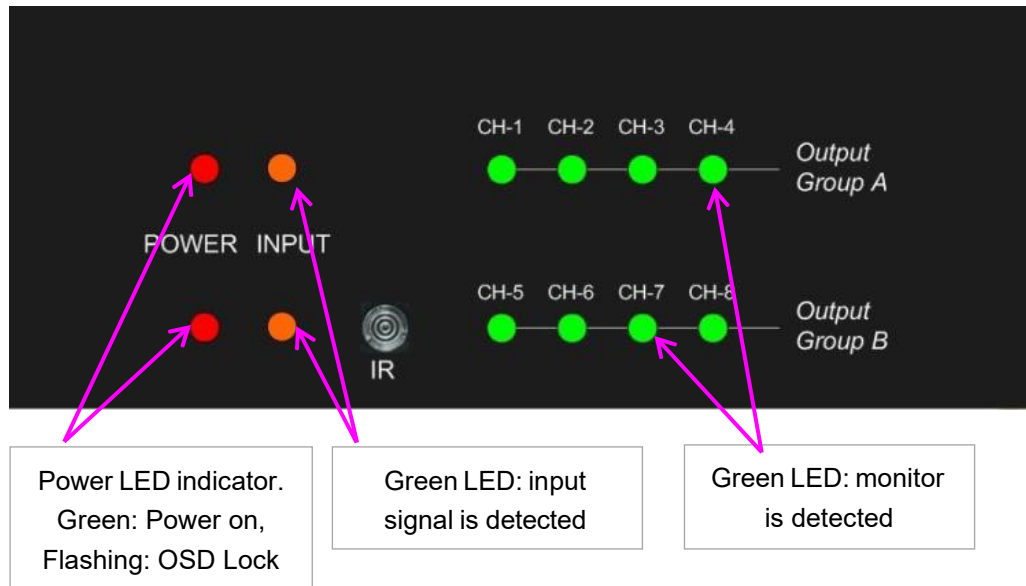

- G408 has only one HDMI input port in each processing module. System default input is HDMI. No need to change.
- HDMI 2.0-A input is only for Module A and HDMI 2.0-B is only for Module B. If user wants to apply the same input source to both display Modules, please connect through Loop Out port.
- The output resolution selection will apply to two output channels at the same time. For instance, CH1 & CH2 will have the same output resolution. it can be setup through CH-1 or CH-2. The same output resolution setting can be applied to CH-3/CH-4, CH-5/CH-6 & CH-7/CH-8.
- Green LED will light up on the keys if the output had been connected with monitor.
- **If continuous flashing in Power key LED at 0.5" interval, it means the OSD function has been Locked. Please press [Menu] key for 5 seconds to disable [OSD Locked] function. If user sets menu lock through remote controller, the Power key LED will be flushing at 1.0" interval. User needs to press number keys [850] to disable menu lock.**
- Output resolution list: 1024x768 60/120Hz, 1280x720 60/120Hz, 1280x800 60/120Hz, 1280x1024 60Hz, 1360x768 60Hz, 1400x1050 60hz, 1600x1200 60Hz, 1920x1080 24/30/50/60Hz, 1920x1200 30/60Hz, 2048x1080 60Hz, 2048x1200 60Hz & Deep Color.
- **All output resolution is RGB 4:4:4 and progressive. If the input source and display device can support 10-bit color, user can turn on [Deep Color] to display 10-bits color. User can click [INFO] key to check input / output result.**
- User can set EDID to tell input source to output desired resolution. User may need select from PC Display Control Panel to set output resolution again or to re-boot PC to output EDID resolution.
- G408 can support non-VESA standard input timing once signal source can provide, such as 7680x1200 @30Hz or 2400x2400 @60Hz.
- When press [OTH] key to select output resolution, the monitor will resynchronize the timing and it will take few seconds to finish the selection.

- User can click [INFO] key to get system information and see input / output signal resolution.
- The input refresh rate should be the same as output refresh rate so that the system can implement Frame Lock to synchronize all the outputs. If the input source is 50Hz with 60Hz output, then it is possible to see some synchronization issue among the displays.
- User can select output resolution from remote controller. When press [OTH] key, it will show resolution of 1920x1200, 1280x720 and 1360x768 continuously. After release from keypad, the system will apply the selected resolution to the selected output port.
- User can also get into OSD menu to do output resolution settings: [Image Properties]→ [Output Mode]→ Select output resolution
- Input green LED will light up when each processing module has detected input signal.
- Power LED:
 - ✓ Red: Power connected
 - ✓ Green: Power on
 - ✓ Red flashing at 0.5" interval: OSD lock through Menu key
 - ✓ Red flashing at 1.0" interval: Box ID lock through remote controller 85x ID # control key

7. Set 10-bits color output

- If the input is 10-bit signal and the output display device can support 10-bit output, user can set 10-bit output mode through [Image Properties]→ [Output Mode]→ [ON]
- User can click [INFO] key on remote controller or front panel keypad to check input / output timing result.
- **Each Processor should execute this setting separately.**

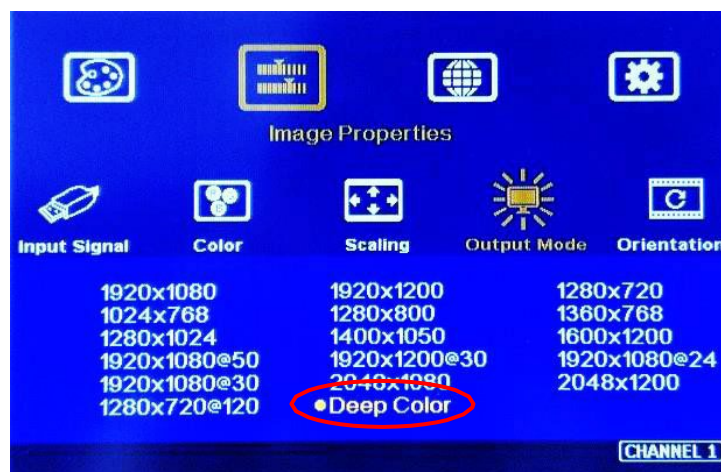

8. System setting: Box ID, RS232, Ethernet

- **Box ID, RS232 and Ethernet settings shall be executed through CH-1 or CH-2. Please connect CH-1 or CH-2 with monitor if user wants to see the system settings through OSD.**

- User can set different IP address in each G408 through Ethernet, USB or remote controller so that each G408 can be controlled independently. Default IP address is 192.168.0.100.

8.1. Box ID

- The range of Box ID is 0 ~ 99 for RS232 command.
- If user uses remote controller to do system operation, the Box ID range is 0 ~ 9.

8.2. RS232 settings

- RS232 is designed with DB-9 connector. User can select baud rate between 11520 and 9600.
- We can provide UART protocol for the control from RS-232, USB, or Ethernet.

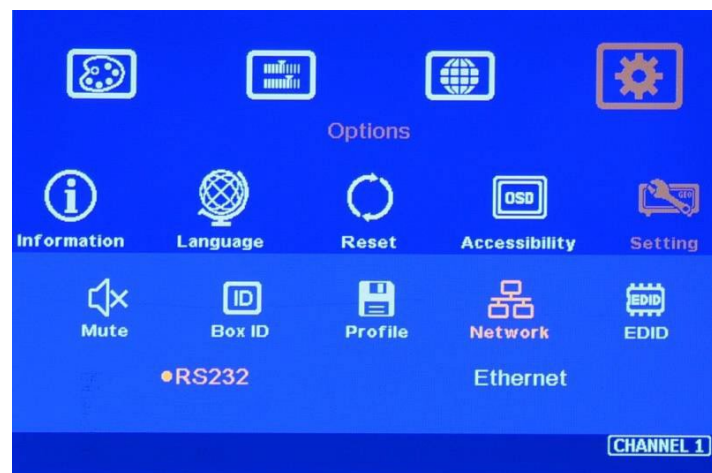

8.3. Ethernet

- User needs to connect G408 to WiFi Router or switch/hub through RJ45 to LAN port. Then user can control the system through Ethernet.
- Crossover UTP cable can be used for direct connection between PC and GeoBox. User needs to set PC TCP/IPv4 with the same domain segment as GeoBox (for instance, to set IP address at 192.168.0.105) and subnet mask at 255.255.255.0).
- Open web browser (Google Chrome or Internet Explorer) and input G408 IP address (default is 192.168.0.100), user can see GeoBox WebGui and menu with virtual keys similar to OSD for further system operation. There is no additional software is required.
- User can set DHCP for the connection. If necessary, please [Renew] DHCP to get IP address before network connection.
- UWM is another web tool that has full function for system setting and operation. It can also update Firmware or MCU code. UWM can be downloaded from <https://www.geoboxav.com/download-center> website.
- Each G408 can set different IP address for independent operation and control.
- Please use < > OSD keys to select OSD menu items and use ^ v OSD keys to change IP address.

- If GeoBox is connected with WiFi Router (through LAN port), user can control GeoBox through WiFi via PC, iPad or mobile phone.
- Default TCP server port is 1266.

Please note: RS232 and Ethernet are available for system control. They can be used simultaneously to provide the most flexibility in system control.

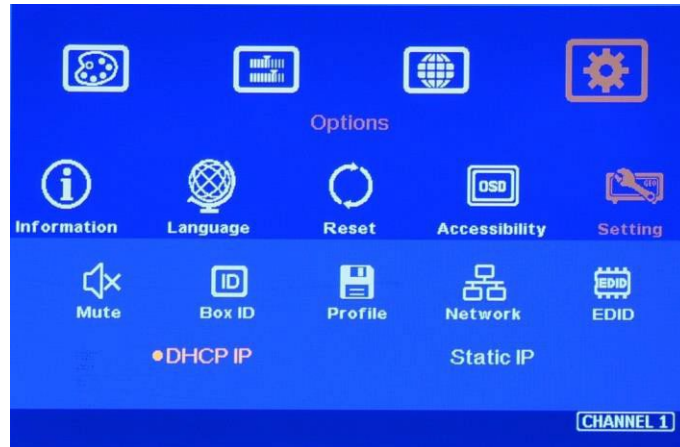

9. Video Wall Settings

Different input resolution may have different Video wall settings. User needs to apply signal source before video wall setting. Once it is done, the system will automatically change the parameters to adopt different input resolution.

Press [Video Wall] hotkey on Front Panel or Remote Controller to activate [Video Wall] menu. WebGui and UHDWall Manager (UWM) PC tool are available for Ethernet configuration.

Note: Image 90/270 flip and rotation are only available when input resolution is under 4k/2k @30Hz.

9.1. [Zoom]

Use [Zoom] to split the display in horizontal and vertical directions. GeoBox will cut the image into different sections. Maximum split image is 15 in both horizontal and vertical directions.

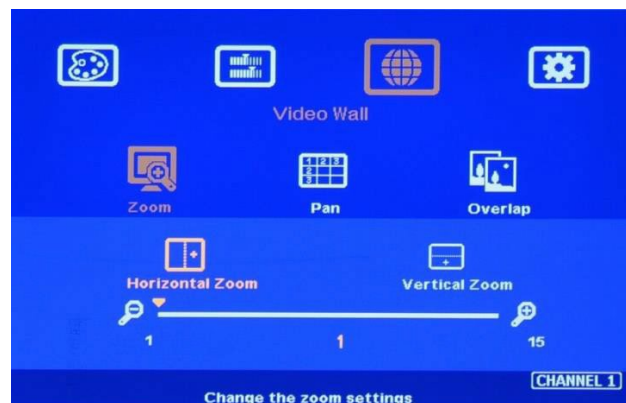



For 3x1 displays

Horizontal Zoom = 3, Vertical Zoom = 1

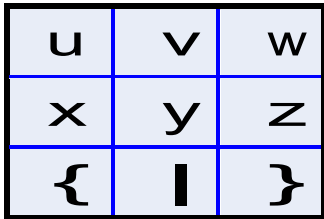

For 3x3 displays

Horizontal Zoom = 3, Vertical Zoom = 3

9.2. [Pan]-Assign image position

[Pan] will assign the location of each split image in the display in both horizontal and vertical directions. Horizontal direction is counted from Left to Right and Vertical direction is counted from Top to Bottom.

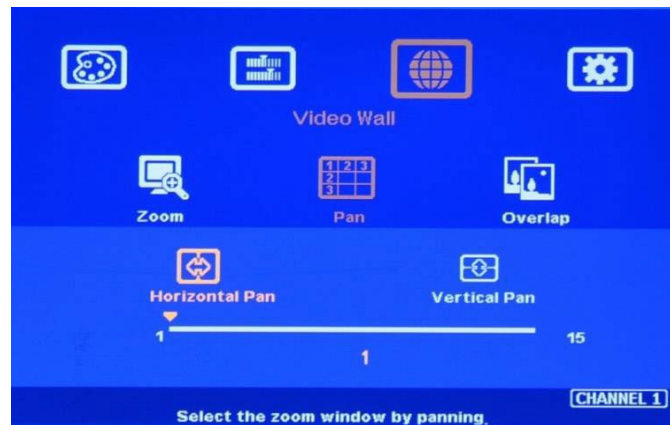

In the case of 3x3 display, Pan settings are as below:

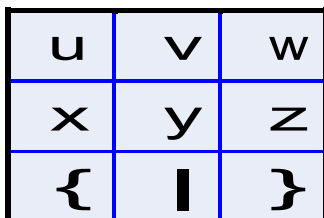

For No. W monitor:

Horizontal Pan = 3

Vertical Pan = 1

For No. Z monitor:

Horizontal Pan = 3

Vertical Pan = 2

9.3. [Overlap] – and Position Alignment

[Overlap] adjustment changes the cropping area of the source image so that image position in each monitor will be shifted. It can compensate Bezel Size of the monitor and correct misalignment in monitor installation. If overlap value is decreased, each monitor will capture less image area and cause [zoom in] (enlarged) effect. If overlap value is increased, each monitor will capture more image area and cause [zoom out] (shrunk) effect. User can also use this function to correct position mis-alignment in installation, shift image location for irregular video wall and set overlap area for projector edge blending application.

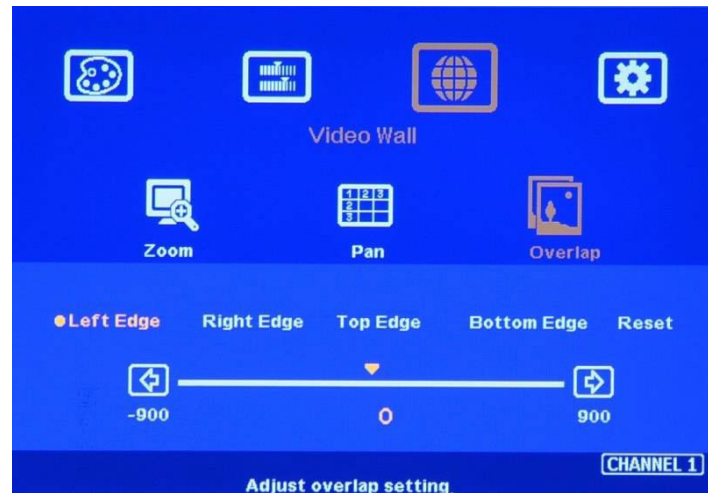

- Maximum [Overlap] adjustment value is 1800 pixels in all directions.
- User can see the image and select Edge to adjust [Overlap] value for Bezel compensation and to adjust image mis-alignment due to monitor installation issue.
- User can use [Overlap] function to stretch the image outside video wall (some image will be missing) or draw image inside video wall with Black blanking area at the edge. This function can adjust the aspect ratio of the content to meet required aspect ratio of the video wall. Please see more details in [Flexible Aspect Ratio Adjustment] section.
- Asymmetric video wall can be achieved through overlap adjustment even with different size of monitor and bezel dimension.

9.4. 3x3 Video Wall setup

Below is 3x3 video wall with one G408 and one G406s instead of two G408 to reduce the cost. G406s is dual channel video wall controller. Different model GeoBox can work together.

- Signal source: all GeoBox must receive the same signal source through loop out port connections.
- Output Port: No specific connection sequence is required.
- Zoom: To set H (Horizontal) = 3, V (Vertical) = 3 in all channels.
- Pan: to set PAN based on the actual connection position.
- TV1: H=1, V=1, TV2: H=2, V=1, TV3: H=3, V=1, TV4: H=1, V=2, TV9: H=3, V=3
- Overlap: If the bezel of each TV is less than 3.5mm, usually, it is not necessary for overlap adjustment. If user wants to do bezel compensation, please see below section for more details.
- User can use Overlap to adjust the image position in each TV to compensate mis-alignment during installation.
- If different size TV is used, user can also compensate image location through Overlap adjustment.
- The TV can be installed at 90/180/270 rotation. User needs to rotate the image based on each TV direction through [Orientation] under [Image properties] menu, then to do [Video Wall] menu setup.

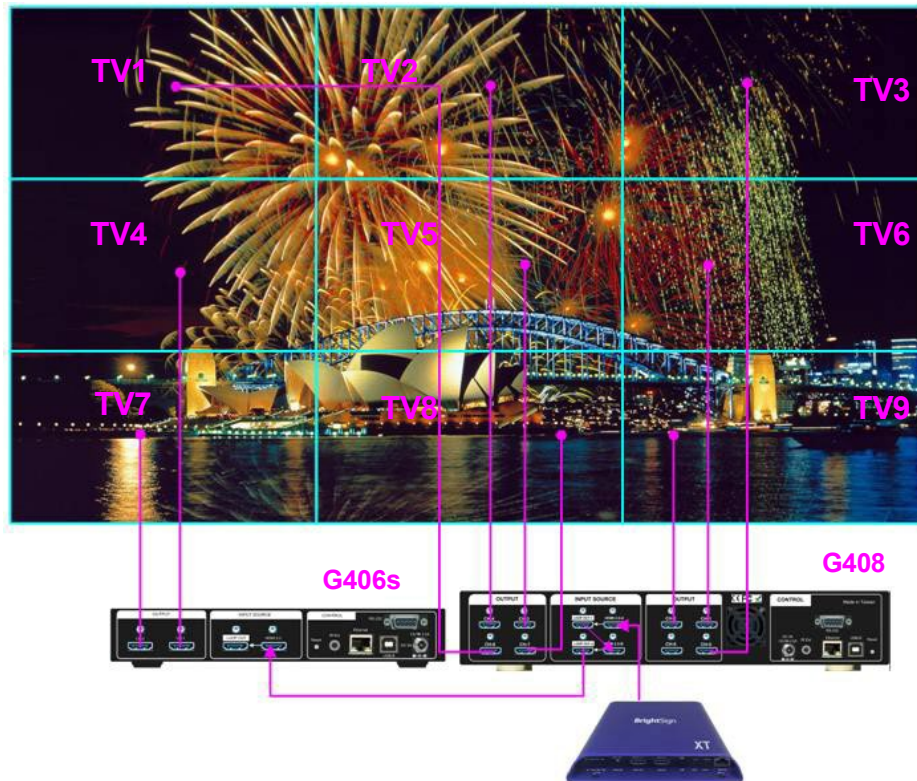

9.5. Bezel Compensation

- Through [Overlap] menu, user can adjust image cropping area and adjust image position.
- User can apply test pattern and reduce [Overlap] value to enlarge the image to the bezel center line between two monitors to achieve bezel compensation.
- User can also calculate the pixels number for bezel compensation based on the video wall dimension and bezel size. If the video wall active display area is 360cm in width and the input source is 3840, then the pixel number for each centimeter is $3840/360=10.67$ pixel/cm. If the bezel size is 12mm in one edge, then user can decrease Overlap value $10.67*1.2=12.8$ (13) pixels to do bezel compensation for that edge (to enlarge the image 13 pixels at that edge).
- User can apply the same method to correct the position mis-alignment in monitor installation or set image position for irregular video wall.

10. OSD Lock and Unlock

- User can hold [MENU] key on front panel or remote controller for 5 seconds to lock OSD to prevent someone to change the settings. After OSD menu is locked, user will see flashing LED on Power key on the front panel at 0.5" interval.
- User can hold [MENU] again for another 5 seconds to unlock OSD and do further operation.
- User can set Box ID for each G408 and control via remote controller:
 - ✓ Press [851] · all the box OSD will be locked except ID #1 G408. The [INFO] LED will be lighted in the locked unit and only ID #1 G408 can be operated.

- ✓ Press [853] · all the box OSD will be locked except ID #3 G408. The [INFO] LED will be lighted in the locked unit and only ID #3 G408 can be operated.
- ✓ Press [850] · all the box OSD will be unlocked and can be operated through remote controller.
- ✓ The units have been locked will show flashing Power LED at 1.0” interval.

11. Save and Load system settings

11.1. Save System Settings through IR remote controller and OSD Menu

- After finishing system settings, user can save the setting by OSD menu through [Menu]➔ [Options]➔ [Setting]➔ [Profile]➔ [Save]➔ [Index 1-5].
- [Save] Profile from OSD menu will take effect for one Processor (two channels) only. User needs to Save CH-1 / CH-2, CH-3 / CH-4, CH-5 / CH-6, CH-7 / CH-8 separately.
- **User can use [Save] hotkey + Number key on remote controller to save settings directly for all channels at the same time. Don't use Direction key or Enter to select Index #, Otherwise, it will save only for two channels.**
- Five different display settings can be saved to [Profile]. The data stored in Profile include EDID setting, input source, output resolution, color settings and all user customized settings.

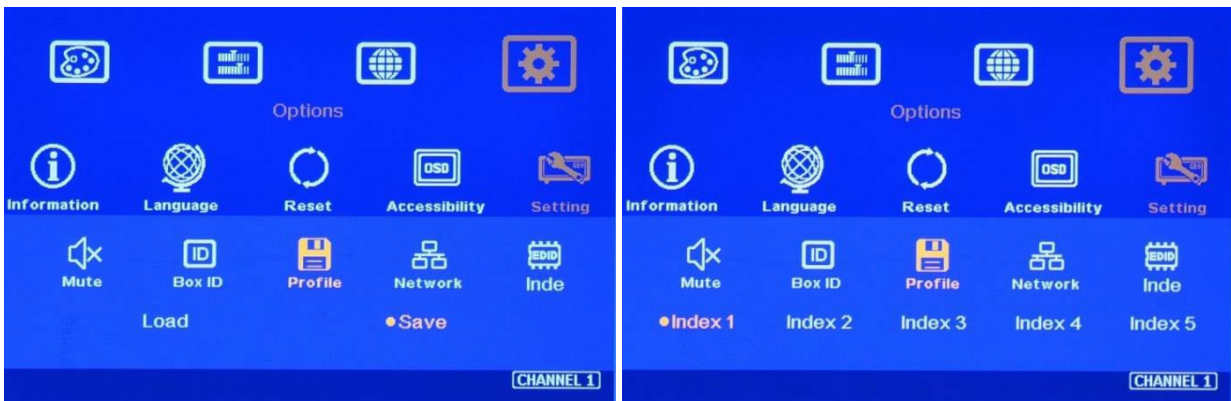
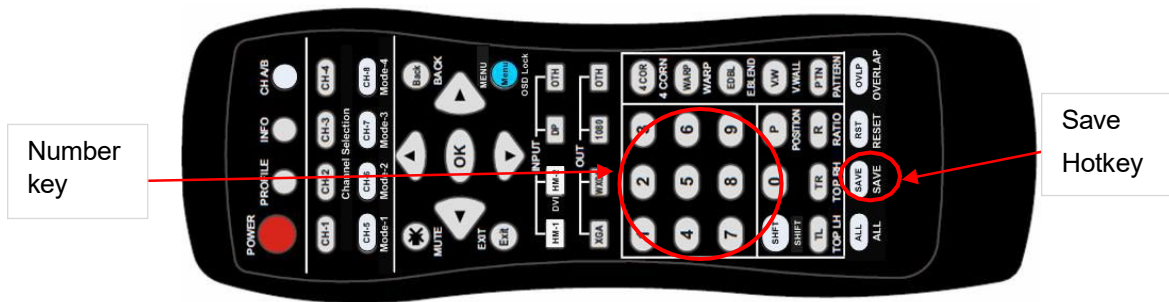

- When user power off the system, GeoBox will keep user setting without loss even the setting is not saved into Profile Index, unless someone to change the setting.
- When system has been reset from OSD menu or update new Firmware, Profile data will still be kept inside G408.

11.2. Load Profile settings through remote controller

- Press [Profile] shortcut key in remote controller → Select number keys 1-5 to recall Index 1 – Index 5. Profile Load will apply to all channels at the same time.
- Please don't use Direction key or press Enter to select Index #, otherwise, it will be only functional in one processor.

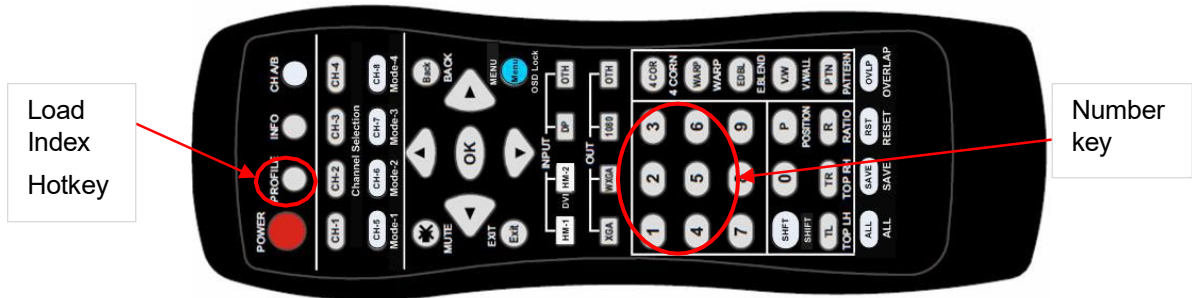

11.3. Load/Save Profile Index through WebGui and UWM PC Tool

- Profile [Load] and [Save] button under [System] menu are available to Load and Save profile settings.
- Load and Save will apply to all channels at the same time.

12. System Reset

User can reset system through below method:

- User small pin to insert RESET hole at back panel for 5 seconds, user will see [Reset to Default] message. It will apply to all channels at the same time. It will also delete the data saved in Profile Indexes.
- OSD menu to reset the system will only be functional for one Processor--two channels.
- [Reset] hotkey on remote controller will access RESET OSD menu directly and only reset one Processor at one time. Please reset each Processor separately.
- When operating through OSD or remote controller, user can select to reset [Reset All] or only reset [Video Wall setting] setting.
- Reset through [Reset] hole on the back panel will clean [Profile Index] settings.
- Reset through [Reset] hotkey on the remote controller or OSD menu, [Profile Index] settings will not be deleted.

13. Irregular / Asymmetric Video Wall Settings

13.1. Introduction

- Asymmetric video wall can be created by rotating monitor installation direction or position. User can crop different area image for each monitor, rotate image direction and adjust image position through G408 to achieve it.

Note: Image flip and rotation are only available when input resolution is under 4k/2k @30Hz.

- User can use monitors with different dimensions, bezel size and resolution as display devices. No data base for monitor is required and it allows user to have some deviation in installation position. All of these factors can be corrected by GeoBox video wall settings.
- G408 can only rotate the image at 90/180/270 degrees. The monitors need to be installed at landscape or portrait position. If users want to install monitor at other rotation angle, G413 model should be used.

13.2. Wind-Mill Asymmetric Video Wall Setup Procedures

- **System connection (example)**

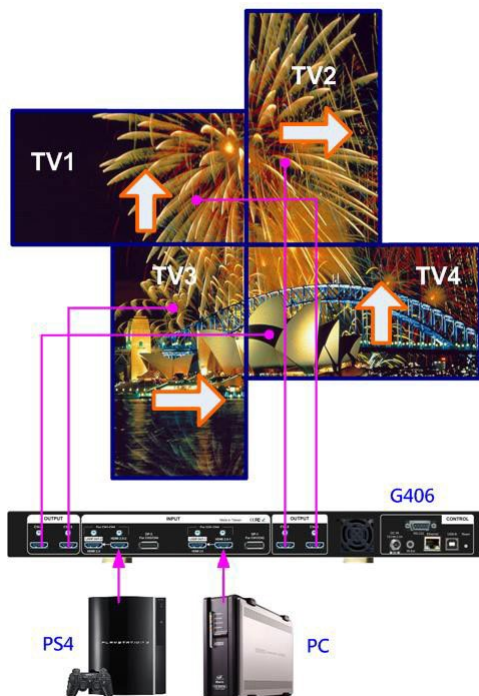

- Monitor can be different bezel size, screen dimensions, and resolution.
- All monitors can be installed at 90 / 180 / 270 degrees display direction.
- Each monitor can be connected with any output port. (In this example, CH1→ TV1, CH2→ TV2, CH3→ TV3, CH4→ TV4)
- User can select any signal source (i.e. PS4 or PC) to display on video wall.
- Able to display both signals from PS4 & PC at the same time.
- Below setup example is based on the drawing as showed left.

- **Apply test pattern from signal source**

Below test pattern should be applied as signal source for easy setup. Please download from below website: <https://www.geoboxav.com/download-center>

User can open test pattern with "Paint" PC software (inside Windows 10) with full screen display to show full screen test pattern.

Test pattern downloaded
from GeoBox website

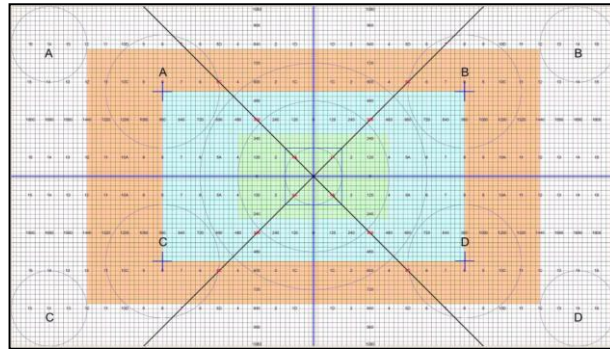

Test pattern
applied to video

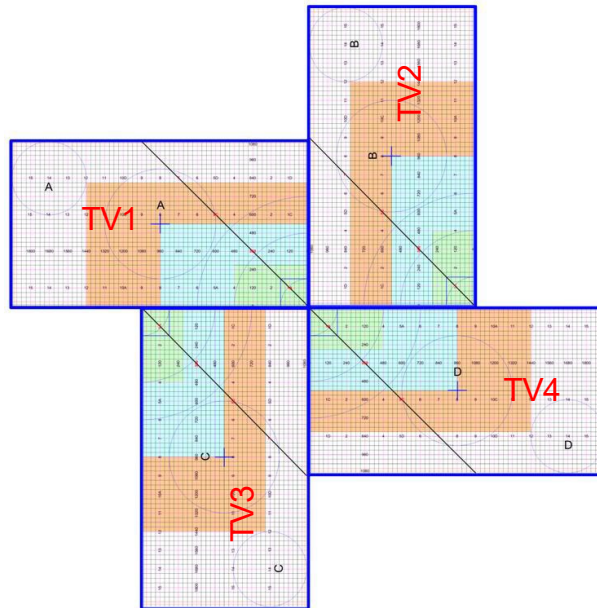

- **Split the content by [Zoom]**
 - Set [Horizontal Zoom] =2, [Vertical Zoom] =2 in all channels.
 - If TV2 & TV3 horizontal dimension is small, user can set TV2 & TV3 [Horizontal Zoom] = 4 and [Horizontal Pan]: TV2=3, TV3=2, so that user can reduce the image position adjustment range.
- **Assign image location by [Pan]**
 - Set [Horizontal Pan]: TV1=1, TV2=2, TV3=1, TV4=2
 - Set [Vertical Pan]: TV1=1, TV2=1, TV3=2, TV4=2
- **Image rotation**

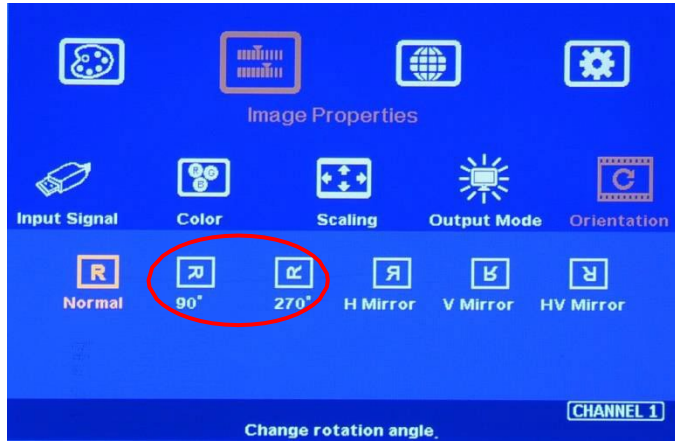

Use [Orientation] menu to rotate images in TV2 and TV3 to display the same image direction.

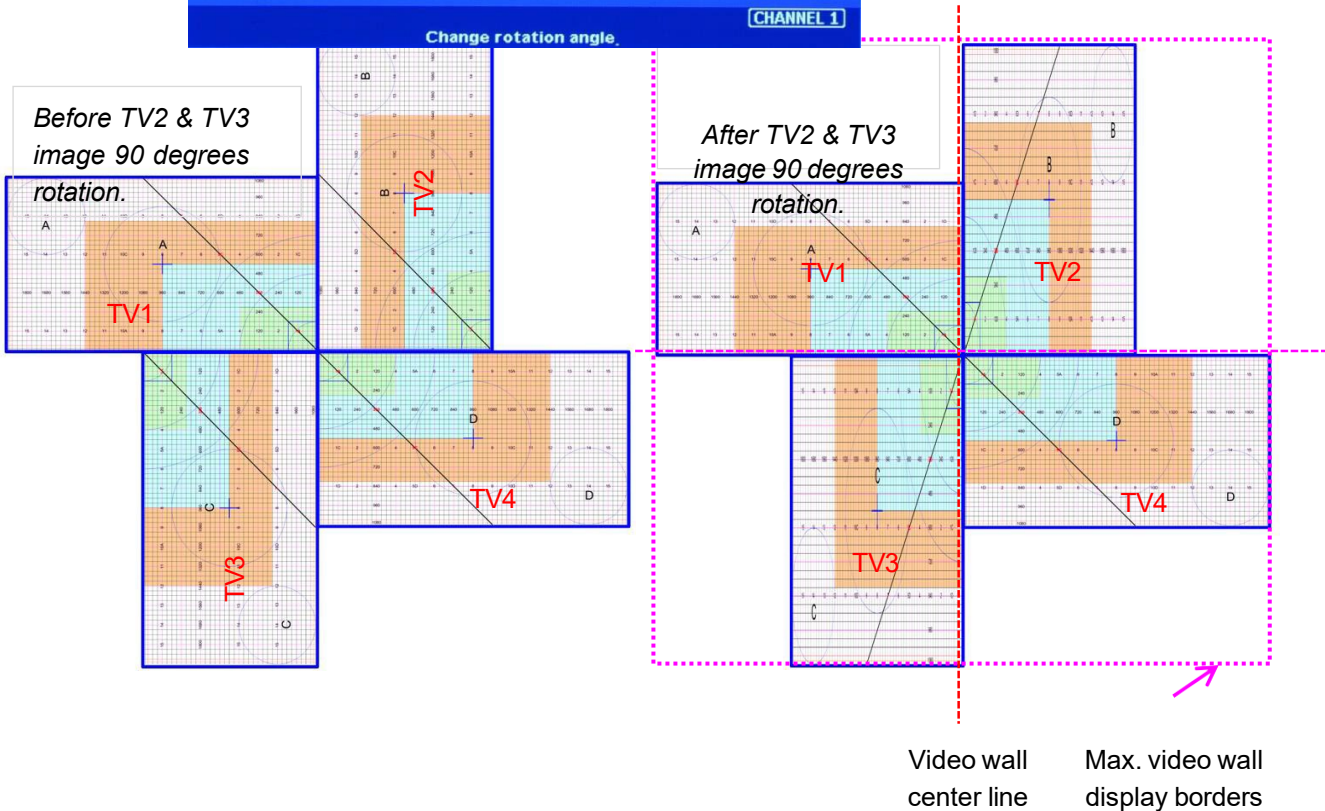

- **Set standard position as reference in horizontal and vertical directions**
 - User should determine Horizontal & Vertical image sizes and reference position so that all monitors have criteria for image position adjustment.
 - Usually, image display borders are the maximum active display borders in the video wall.
 - In the above example, the horizontal borders are decided by TV1 & TV4. Vertical borders are decided by TV2 & TV3.
 - User can decide video wall display center through test pattern. It can be asymmetric.
- **Adjust image position by [Overlap] menu to finalize video wall settings**

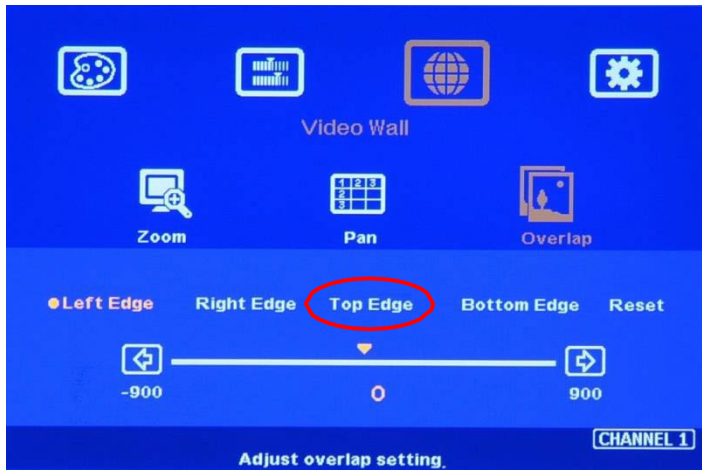

1. [Overlap] is to change image capture range.
2. Decrease value in Top Edge of TV1 will stretch top edge of TV1 to match image position of TV2.
3. For TV2 adjustment, user needs to adjust Overlap value based on the actual image direction but not based on OSD menu direction. In this example, user needs to stretch Right Edge to match TV4.

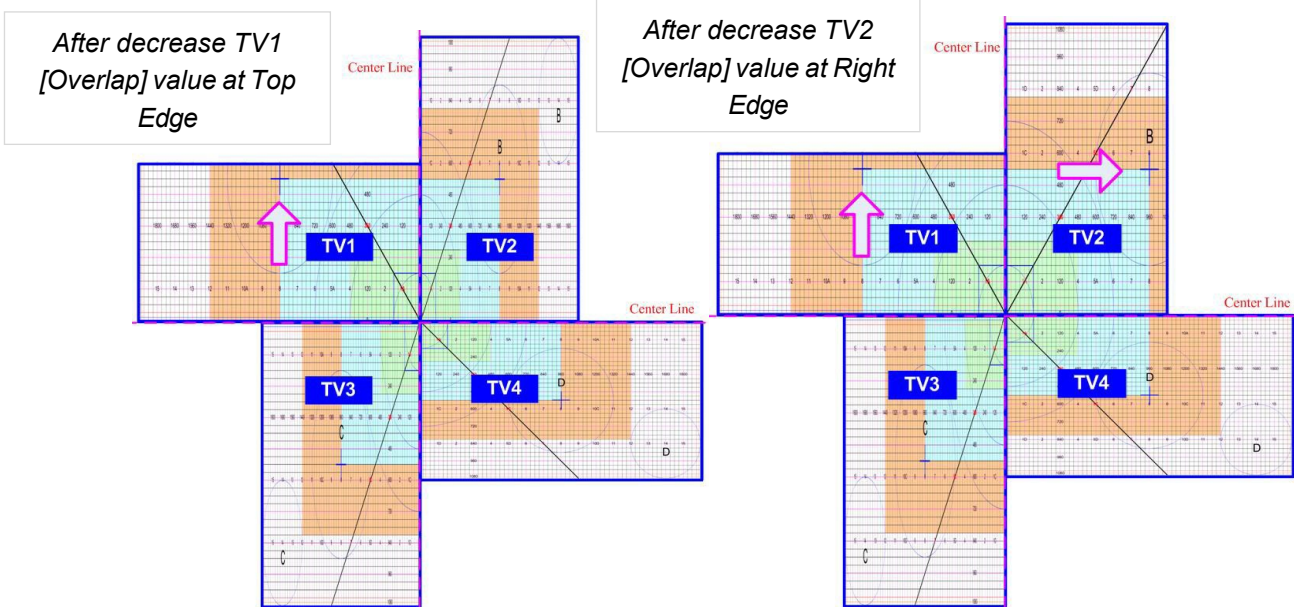

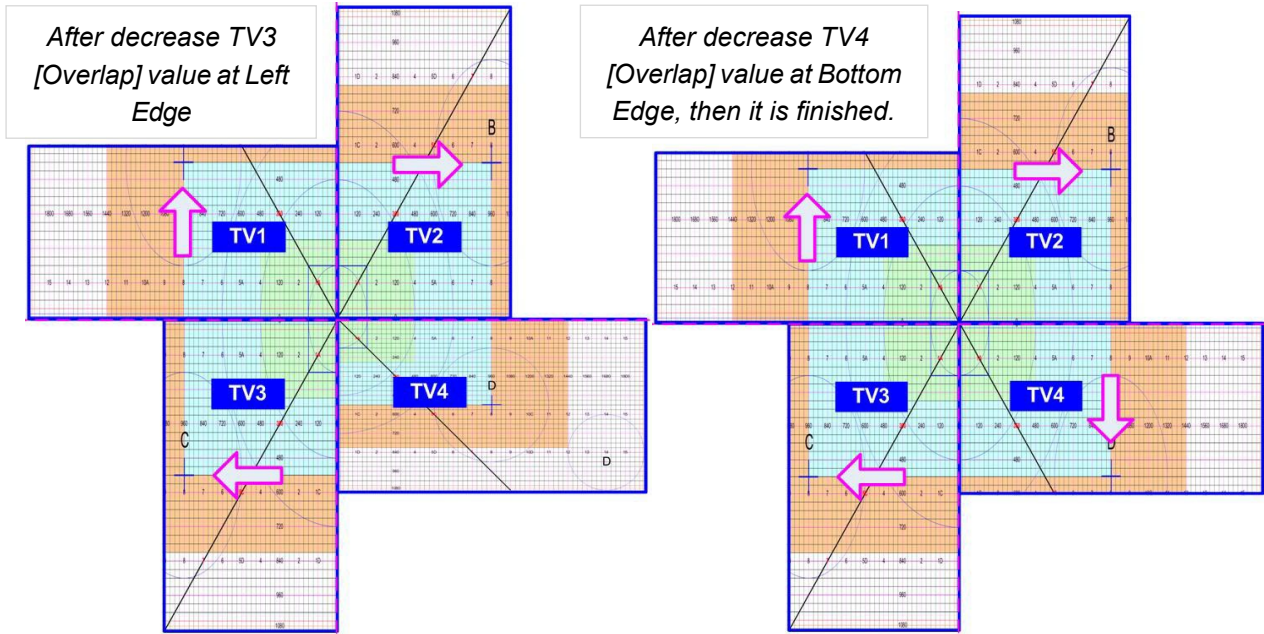

13.3. Square Asymmetric Video Wall Setup Procedures

- Step 1: Video Wall settings for all channels
 [Zoom]: H=2, V=2
 [Pan]: TV1: H=1, V=1, TV2: H=2, V=1, TV3: H=1, V=2, TV4: H=2, V=2
- Step 2: Apply Test Pattern and Rotate TV1 & TV4 images at 90 degrees

Original Image after applied test pattern

Image after image rotation in TV1 & TV4

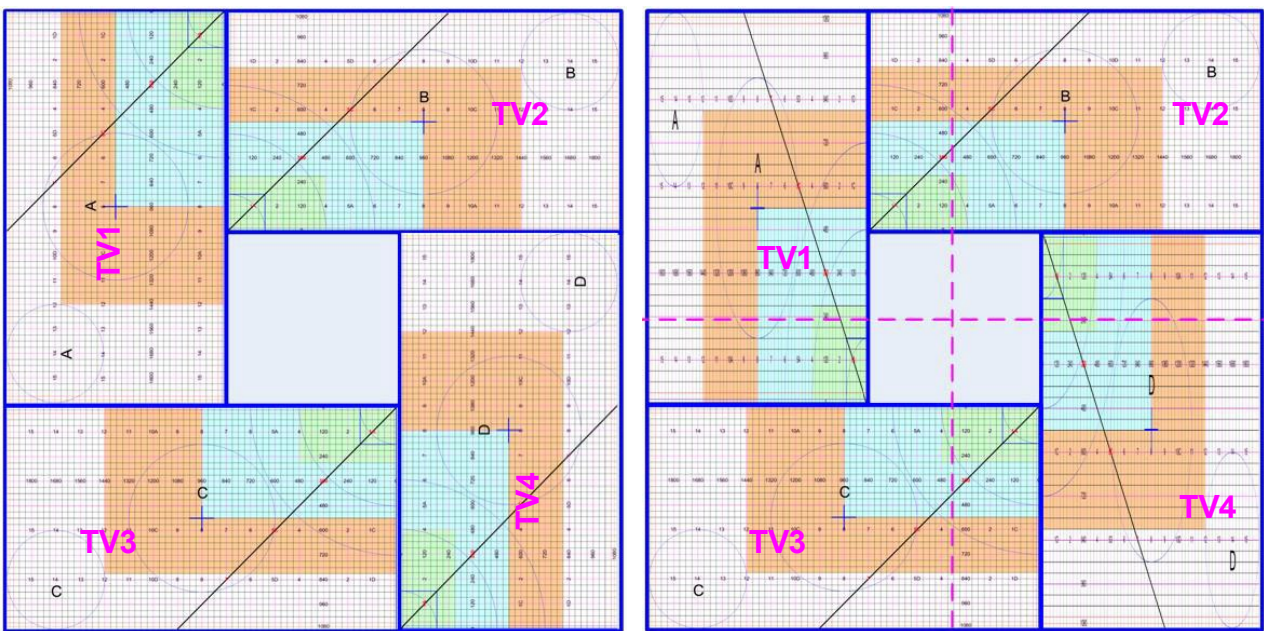

- Step 3: Determined image center, marked with paper tape.
- Step 4: Set standard Position Reference in horizontal and vertical directions

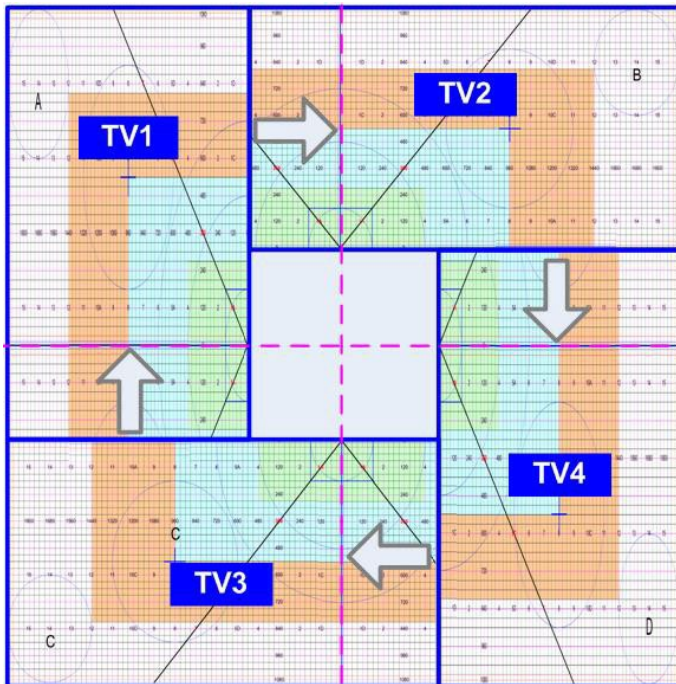

- ✓ Horizontal Position Reference is determined by TV2 & TV3 and Vertical Position Reference is determined by TV1 & TV4.
- ✓ Once user can line up the image center to Video wall center H&V lines, it can serve as Position Reference lines.
- ✓ Left figure shows the result after setting Horizontal and Vertical Position Reference (Move TV1 center line up, TV2 center line to Right, TV3 center line to Left and TV4 center line to down—please see the arrow direction)

TV1: increase [Overlap] value in Bottom Edge to move Horizontal center line up to video wall center

TV2: increase [Overlap] value in Left Edge to move Vertical center line right to video wall center.

TV3: increase [Overlap] value in Right Edge to move Vertical center line left to video wall center.

TV4: increase [Overlap] value in Top Edge to move Horizontal center line down to video wall center.

- Step 5: Individual monitor position adjustment based on Horizontal and Vertical Position Reference resulting from the previous step 4.

TV1: increase [Overlap] value in Left Edge and decrease [Overlap] value in Right Edge to align Vertical lines to match TV3

TV2: increase [Overlap] value in Top Edge and decrease [Overlap] value in Bottom Edge to align Horizontal lines to match TV1

TV3: increase [Overlap] value in Bottom Edge and decrease [Overlap] value in Top Edge to align Horizontal lines to match TV4

TV4: increase [Overlap] value in Right Edge and decrease [Overlap] value in Left Edge to align Vertical lines to match TV2

- Step 6: After final image position, all horizontal and vertical pattern can be matched together. The setup procedure is finished.

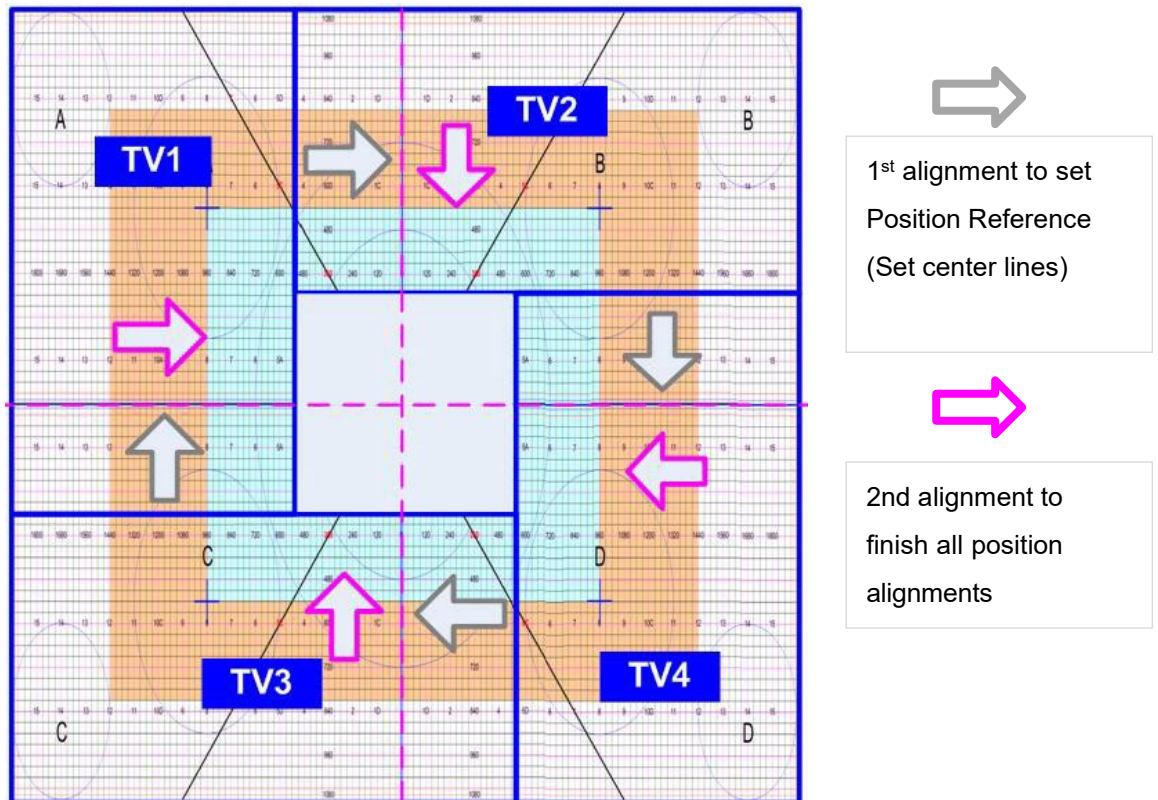

1st alignment to set
Position Reference
(Set center lines)

2nd alignment to
finish all position
alignments

13.4. Aspect Ratio and image distortion

- If the source content aspect ratio is not 1:1 in this Video Wall setting, the final image will have some distortion.
- User can adjust source resolution and content aspect ratio to fix this issue
 - ✓ Set display EDID with 2160*2160 with same ratio as the aspect ratio of Video Wall.
 - ✓ Use PC as signal source with 2160*2160 output resolution and use content with 1:1 aspect ratio. Customized output resolution setting in PC may be required.
- User can also provide 1:1 aspect ratio content and set the PC with 4k/2k output resolution with full screen display in PC output. User will also see none distortion image.
- If source resolution and content don't match the above conditions, user can adjust the display aspect ratio in video wall settings to reduce image distortion but it may have below issues:
 - ✓ With some blanking area at some borders.
 - ✓ Display with full screen but some image will be stretched outside display borders and can't be seen.
- If user wants to change video wall display image aspect ratio, user needs to adjust Position Reference Line first. In this example, if user wants to stretch horizontal image, user needs to adjust TV3 and TV2 horizontal scaling factor first (grid size), then to align TV1 and TV4 to match TV3 and TV2 with test pattern.

13.5. Other Big Scale Asymmetric Video Wall

If there is a video wall required large number of controllers to achieve it, users can have two options:

- A. To adjust image directly through remote control and test pattern
 - To apply test pattern and familiar with test pattern and related positions.
 - To execute [Zoom], [Pan] and image rotation settings.
 - After individual LCD image location is determined, you can use remote control directly to adjust the image location according to the test pattern.
 - The general adjustment order is from the video wall center and outer edges first. If you can adjust the size of the grid in horizontal and vertical directions in some monitors as reference baselines, then all other monitors can be adjusted according to these baselines.
- B. The second way is to do position measurement for each monitor according to design drawing or picture, and use remote control and test patterns to input adjusting parameters directly.
 - First step is to measure H&V active display area dimensions of the complete video wall setup, for example, 400cm X 180cm.
 - Determine the signal source resolution: For example, 3840*2160
 - Calculate the desired display pixel per centimeter: horizontal: $3840/400=9.6$ pixel/cm, vertical: $2160/180=12$ pixels/cm
 - Based on the monitor layout, to execute [Zoom], [Pan] and rotate the image if necessary.
 - When the image position of individual LCD is determined, user needs to measure the distance between corner position of active display area in each monitor and the image location determined by the [Zoom] and [Pan].
 - Using these distances and pixel densities per centimeter, you can calculate the approximate horizontal and vertical position adjustment pixels.
 - Use the remote control to adjust the image position directly according to the calculated value and the test pattern.
- C. Example of an irregular TV wall setting with 8 monitors
 - The actual physical pixel on the upper edge display is: 6000. If the 3840*2160 signal source is used, the signal source pixel on the upper edge is 3840. The actual ratio is $6000/3840=1.5625$. The vertical actual ratio of the $3000/2160=1.3889$
 - When user executes Video Wall [Overlap] setting, it adjusts cropping area of the signal source and changes the image position accordingly.

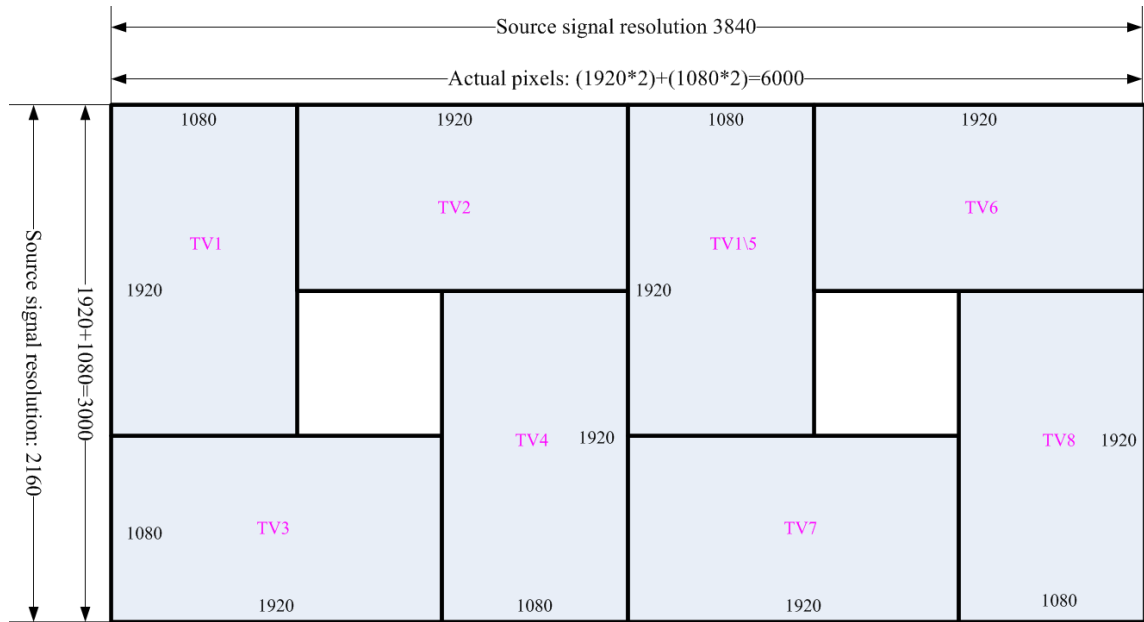

➤ TV1 settings:

- [Zoom]: H=6, V=2, [Pan]: H=1, V=1, [Image orientation]: 90 degrees or 270 degrees.
- When TV1 horizontal zoom is 6, the actual hardware pixel in each horizontal section is $6000/6=1000$. TV1 's vertical zoom is v=2, the actual hardware pixel in each vertical section is $3000/2=1500$
- The horizontal edge of TV1 should be assigned with 1080 pixels, but [Zoom] setting only assigns 1000 pixels to TV1. It is necessary to use the [overlap] adjustment function to add 80 pixels to the TV1. After converting to the signal source pixel, the TV1 [Overlap]➔[Right Edge] adjustment value should be: $80/1.5625=51.2$ Pixel (+51).
- The vertical edge should be assigned with 1920 pixels, but [Zoom] setting assigns $3000/2=1500$ pixels to TV1. It is necessary to use [overlap] adjustment function to add $1920-1500=420$ pixel to TV1. After converting to signal source pixel, TV2 [Overlap]➔[Bottom Edge] overlap adjustment value is: $420/ 1.3889=302.4$ Pixel (+302).

➤ TV2 settings:

- [Zoom]: H=4, V=2, [Pan]: H=2, V=1
- When the TV2 horizontal zoom is 4, the actual hardware pixel in each horizontal section is $6000/4=1500$. TV2 's vertical zoom is V=2, the actual hardware pixel in each vertical section is $3000/2=1500$
- The horizontal edge of TV2 should be assigned with 1920 pixels, but [Zoom] setting only assigns 1500 pixels to TV2. It is necessary to use the [overlap] adjustment function to add 420 pixels to the TV2. After converting to the signal source pixel, the TV2 [Overlap]➔[Right Edge] adjustment value should be: $420/1.5625=268.2$ Pixel (+268).

- The vertical edge should be assigned with 1080 pixels, but [Zoom] setting only assigns $3000/2=1500$ pixels to TV2. It is necessary to use [overlap] adjustment function to decrease $1500-1080=420$ pixel to TV2. After converting to signal source pixel, TV2 [Overlap]→[Bottom Edge] overlap adjustment value is: $420/ 1.3889=302.4$ Pixel (-302).
- TV3-TV8 settings:
 - Below is [Overlap] adjusting value for each monitor without taking bezel compensation into account.

Monitor	Zoom		Pan		Overlap			
	H	V	H	V	LH	RH	Top	Bottom
TV1	6	2	1	1	0	51	0	302
TV2	4	2	2	1	268	0	0	-302
TV3	4	2	1	2	0	268	-302	0
TV4	6	2	3	2	51	0	302	0
TV5	6	2	4	1	0	51	0	302-13
TV6	4	2	4	1	268	0	0	-302
TV7	4	2	3	2	0	268	-302	0
TV8	6	2	6	2	51	0	302	0

- If bezel compensation is required, user needs to enlarge the image in each monitor to the center line between two monitors (some image will disappear). Assume the bezel size is 10mm and the monitor is 42" (active display area is 930*523 mm) °
 - Horizontal pixel density: $3840/ (930*2+523*2+10*6) = 1.295$ /mm
 - The pixel inside bezel is $1.295*1=13$ pixels
- [Overlap] value after considering bezel compensation:

Monitor	Zoom		Pan		Overlap			
	H	V	H	V	LH	RH	Top	Bottom
TV1	6	2	1	1	0	51-13	0	302-13
TV2	4	2	2	1	268-13	0-13	0	-302-13
TV3	4	2	1	2	0	268-13	-302-13	0
TV4	6	2	3	2	51-13	0-13	302-13	0
TV5	6	2	4	1	0-13	51-13	0	302-13
TV6	4	2	4	1	268-13	0	0	-302-13
TV7	4	2	3	2	0-13	268-13	-302-13	0
TV8	6	2	6	2	51-13	0	302-13	0

Monitor	Zoom		Pan		Overlap			
	H	V	H	V	LH	RH	Top	Bottom
TV1	6	2	1	1	0.00	38.00	0.00	289.00
TV2	4	2	2	1	255.00	(13.00)	0.00	(315.00)
TV3	4	2	1	2	0.00	255.00	(315.00)	0.00
TV4	6	2	3	2	38.00	(13.00)	289.00	0.00
TV5	6	2	4	1	(13.00)	38.00	0.00	289.00
TV6	4	2	4	1	255.00	0.00	0.00	(315.00)
TV7	4	2	3	2	(13.00)	255.00	(315.00)	0.00
TV8	6	2	6	2	38.00	0.00	289.00	0.00



Two G408 can build TV wall as Left.

More irregular video wall example:

A. Method 1: Calculate [Overlap] adjustment pixels based on design drawing or installation picture.



- Users can draw an outer frame in the display area using a photo or project drawing.
- Measure the vertical and horizontal dimensions of the outer frame, and divide the resolution of the signal source by the horizontal and vertical outer frame dimensions to get the H&V pixel density per centimeter.
- Measure the distance of the display area in each monitor in both horizontal and vertical positions.
- By using the position distance and pixel density, user can calculate the pixels for position adjustment.
- When user set [Zoom] and [Pan] for each monitor, user can also understand the TV wall cutting position.
- Based on the above information, user can calculate [Overlap] adjustment value. After finishing [Overlap] adjustment, user can apply test pattern and execute position fine-tune.

B. Method 2: Apply test pattern and execute image position adjustment directly

- Users can also align the image directly using the test pattern.
- The image center point is estimated and marked.
- Take the middle monitor TV1 as an example:

- ✓ The center point of the TV wall is in the upper position of TV1.
- ✓ Rotate the image, set [Zoom] as H=5 (about 1/5 in the horizontal direction), V=2 (approximately 1/2 in the vertical position), [Pan]: H=3 (in the 3rd position while H= 5), V=2 (vertical 2nd position).
- ✓ Apply test pattern, select the TV1 connection channel.
- ✓ Use [Overlap] menu to select the top/bottom edge to adjust the vertical position of the test pattern and let the center point of test patten to match TV wall center point.
- ✓ Then adjust the left and right edge [Overlap] value so that the horizontal grid and the vertical grid have similar size.
- ✓ Next step is to set TV2/TV3 [Zoom] and [Pan]: set [Zoom]: H=3 (about 1/3 of the horizontal direction), V=4 (approximately 1/4 of the vertical position). TV2 [Pan]: H=1 (1st position of horizontal direction), V=3 (3rd position of vertical direction); TV3 [Pan]: H=3 (the 3rd position of horizontal direction), V=3 (3rd position of vertical direction), and uses [Overlap] function to let the test pattern align together. If there are some images missing or black borders at both sides, user can shrink/enlarge the TV1/TV2/TV3 grid size, so that the grid can cover full frame of TV wall with the similar horizontal grid size in all TV.
- ✓ The other three upper monitors can be set in a similar manner so that the test pattern can be aligned together and the grid size can be consistent with the other three monitors in both vertical and horizontal directions.
- ✓ If necessary, image fine-tune is required to complete the whole setup.

14. Flexible Aspect Ratio Adjustment

User can use Video Wall [Overlap] function to change the aspect ratio of the image with black borders or to stretch the image in specific direction to compensate the aspect ratio difference between video wall and the content. The Maximum adjustment range is 1800 pixels in each edge.

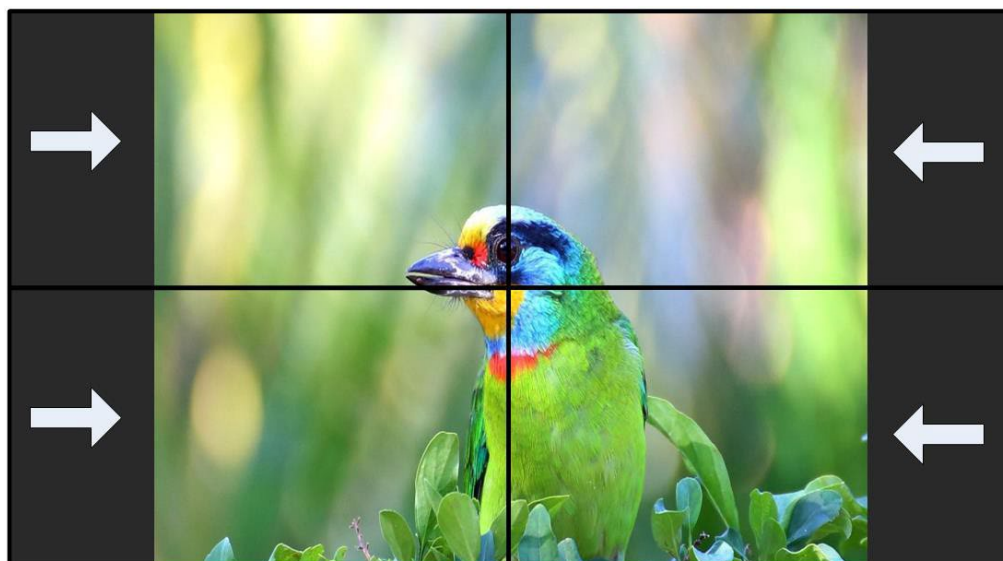

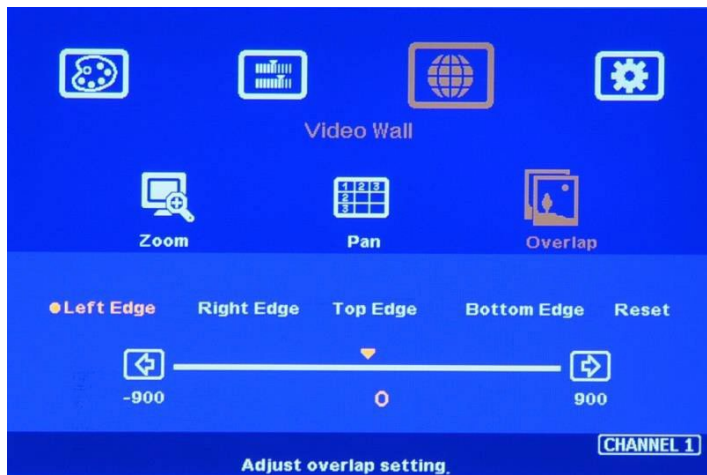

Activate [Overlap] under [Video Wall] menu

- ✓ User can select the channel and the edge required for edge shift, then adjust Overlap value to see aspect ratio change.
- ✓ The image position shift range is ± 1800 pixels in each edge.



- If the image is at portrait position, this function is only available under input signal up to 4k/2k @30Hz.
- If Video Wall [Zoom] is set to H=2 & V=2 or above, user can apply 4k/2k @60Hz input signal. The adjustment range (1800 pixels) is calculated based on signal source resolution.
- When user adjusts Overlap value in one monitor, it will also change the scaling factor. User needs to adjust the Overlap value in other monitors to let all monitors has the same scaling factor.
- **The** adjustment range of 1800 pixels is calculated according to the signal source resolution. If the signal source is 1080p and the adjustment value is 450 pixels, when switching to 4k/2k input signal, the adjustment value will be converted to 900 pixels automatically to maintain the same image position. **If the input signal source is 1080p and the adjustment value is 1800 pixels (maximum), when switching to the 4k/2k input signal, the adjustment value will be kept at 1800 pixels (it should be double but the maximum is only up to 1800 pixels), and the image position will be not the same as 1080p.**

15. PC tool

- **Each G408 has independent IP address. The default IP address is 192.168.0.100. User can set different IP address in each G408 and control multiple units of G408 at the same time.**
- **Two PC tool is available for the control of GeoBox:**
 - ✓ **WebGui: embedded inside G408. No additional software is required.**

- ✓ UHDWall Manager (UWM): HID PC tool, can be used through USB or Ethernet connection without installation process.

15.1. WebGui

- WebGui is embedded inside G408. Once user connects G408 with PC through Ethernet, user can access WebGui and execute all operation similar to OSD menu through Virtual Keys and OSD Menu. No PC or appropriate software tool is required.
- User can turn on/off the system through WebGui and see the status through power indicator.
- WebGui can be controller through mobile phone. Please note that iPhone may have different behavior and cause some mistake.
- In WebGui operation, the icon in the slide bar may need to move to middle point to take effect.

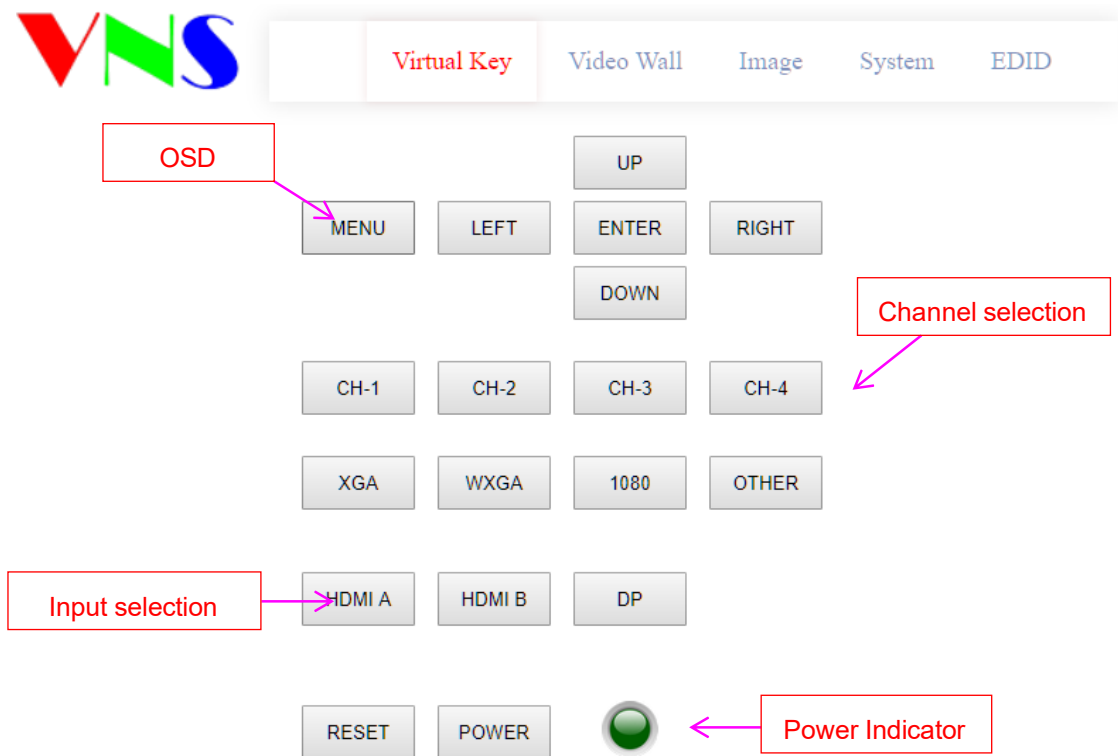

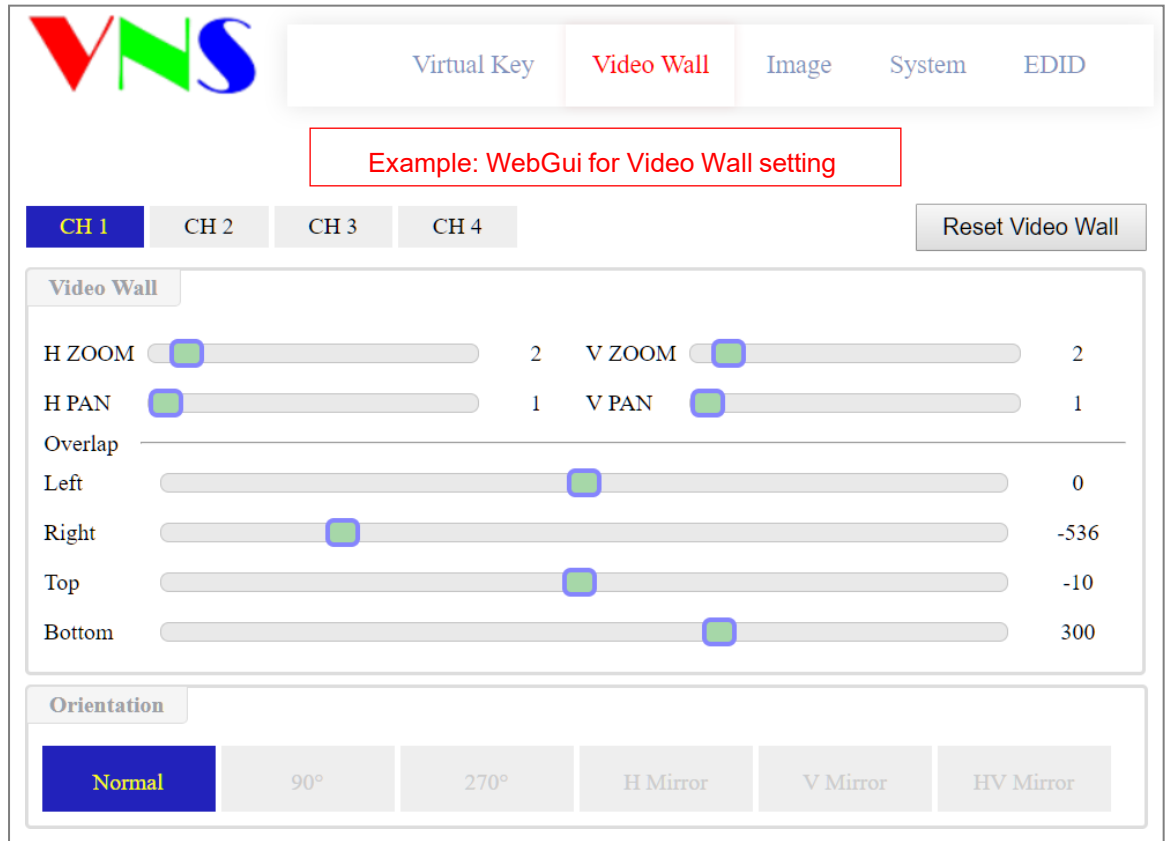

15.2. UHDWall Manager (UWM) PC Tool

- UWM Manager is a PC tool executed through PC. User needs to download this tool from <https://www.geoboxav.com/download-center> website. Once user connects G408 with PC through Ethernet or USB and open UWM Manager, user can access UWM and execute all operation similar to OSD menu through PC keyboard and mouse. User can backup system setting in PC and restore/copy to other units.
- UWM is for system setup and can't read back the settings parameters from GeoBox.
- UWM PC tool is designed for G400 series product. If user connects with G408, user will see 8 channels for selection instead of 4 channels.
- User can execute full operation functions and also update Firmware and MCU code through UWM. User can control multiple units at the same time through change IP address.

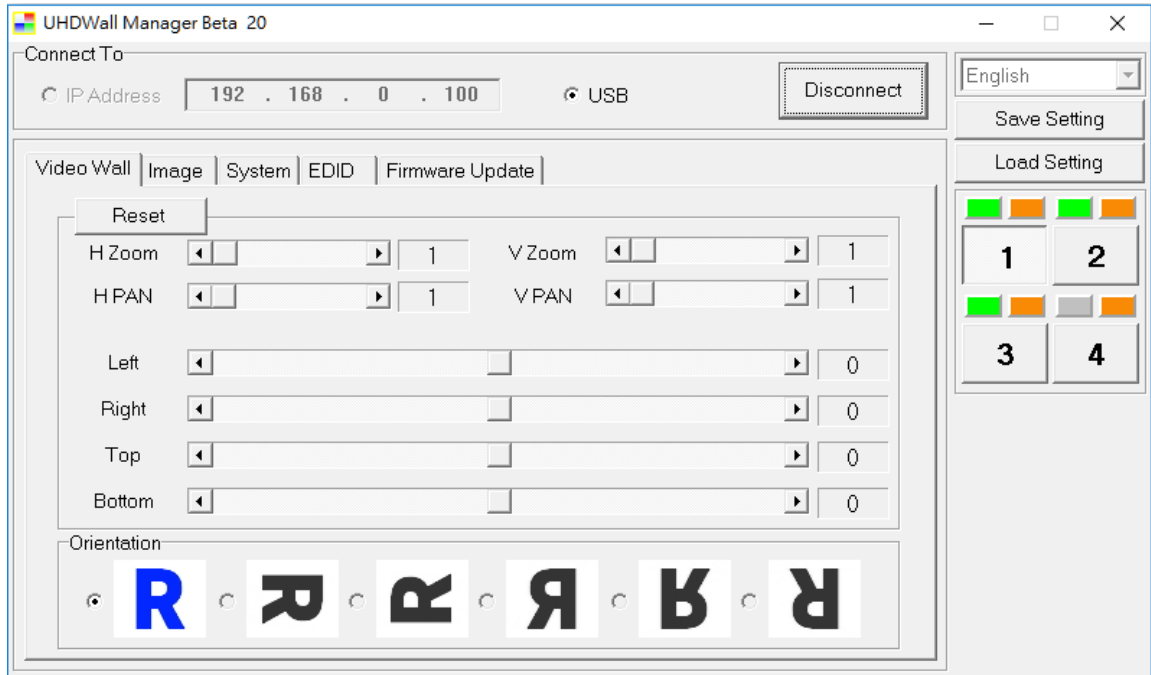

The color icons on the top of CH indicator is to show the system connection status. Green indicates that the channel has connected with display device and input LED indicates that input signal is connected. In the above example, channel 4 output is not connected with monitor.

16. System Structure and Operation behavior

Please see detailed block diagram of G408 on page 6.

16.1. System Structure: Display Processor 1-4

- G408 can be treated as one 8 channel processor or two Quad channel processors. It has 4 processors. Each processor controls two Channels.

16.2. OSD Command Execution in all channels at the same time.

- The following command will be applied to all channels at the same time.
 - [Profile]→ [Load]→ [Index]
 - [Options]→ [Setting]→ [Box ID]: one G408 has one Box ID and can only be set by CH1 or CH2.
 - [Options]→ [Setting]→ [Mute]
 - [Options]→ [Setting]→ [Network]: one G408 has one Network setting and can only be set by CH1 or CH2.
- The following commands will be applied to each processor separately. The commands will apply to two channels inside the same processor.
 - [Image Properties]→ [Scaling]: select full screen or original aspect ratio
 - [Image Properties]→ [Output Mode]: select output resolution & set 10-bit output mode.
 - [Options]→ [Information]: show system information

- [Options]→ [Language]: select OSD language
 - [Options]→ [Reset]
 - [Options]→ [Accessibility]→[OSD Time Out]
 - [Options]→ [Accessibility]→[Logo Time Out]
 - [Options]→ [Accessibility]→[Standby Time]
 - [Options]→ [Accessibility]→[Black Screen]
 - [Options]→ [Setting]→[Mute]
 - [Options]→ [DVI Output]
 - [Options]→ [Frame Sync]
 - [Options]→ [Setting]→[Profile]→[Save]
 - [Options]→ [Setting]→[Profile]→[Load]: If through below OSD operation ([Menu]→ [Setting]→ [Profile]→ [Load], the result will apply to each Processor only. If via [Profile] hotkey on front panel or remote controller to Load Index, the result will apply to all channels at the same time.
- The following commands will be applied to each channel independently.
- Color adjustment: All menu under [Picture]
 - [Image Properties]→ [Color]
 - [Image Properties]→ [Orientation]

17. Miscellaneous features

17.1. EDID Setting

- [Options]→ [Setting]→[EDID]. [Customize] EDID is in the selection list. The range is H= 1024~3860, V= 720~2400.
- HDMI: select CH1 or CH2 with HDMI input, then to set EDID
- User can set EDID directly through WebGui and UWM by selecting input port.

17.2. HDMI vs. DVI Output Signal

HDMI digital signal is compatible with DVI signal. Most of display devices can support both digital signals. Some old equipment may have less flexibility in digital signal compatibility. In this case, user may need to select DVI output format for normal display. Each Processor shall be set separately.



17.3. System Standby and Automatically Turn Off Output Signal

- [Options]→[Accessibility]→[Standby Time]
- If set [Standby Time] at 60, the system will get into Standby Mode after 60 seconds when no input signal is detected. The output signals from G408 will also be terminated at the same time. If G408 detects input signal again (hot plug 5V signal), it will automatically turn on the system again.
- If the monitor can automatically turn off/on by detecting input signal, user can control signal source to execute entire system on/off control.

17.4. Change Background Color

When no signal input, the system will show blue color background with [Power Saving Mode] message on the screen. User can change background color to black from the OSD menu as below.

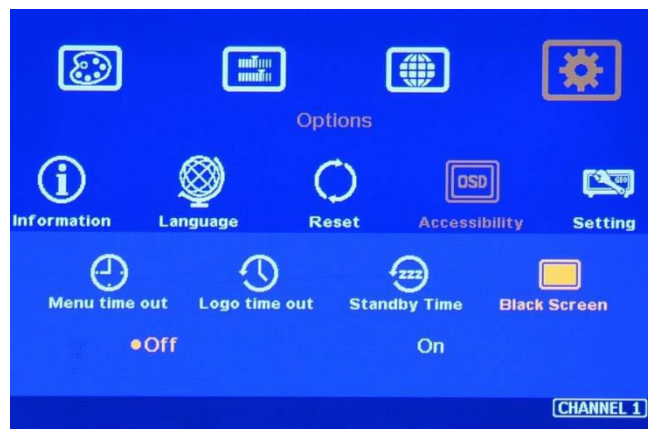

17.5. Change OSD Menu display time

User can set [Options]→[Accessibility]→[Menu time out]→[0] to display OSD menu all the time. Each Processor shall be set separately.

17.6. Change Splash screen logo display time

User can set [Options]→[Accessibility]→[Logo time out]→[0] to eliminate splash screen Logo. Each Processor shall be set separately.

18. Helpful tips for video wall settings

- Image distortion and aspect ratio issues
 - If the content aspect ratio is different from video wall, it will cause image distortion. User can adjust aspect ratio through [Overlap] settings. However, you will have two choices:
 - ✓ Full screen display but some content will be drawn to outside border and missing.
 - ✓ Draw the image into video wall and keep some blanking border at some edge.
- If the signal is from PC, user can set customized EDID in GeoBox to let PC output expected output resolution. Some PC may not follow GeoBox EDID resolution setting and require customized output setting from display card or reboot PC system.

- User can set different video wall settings in each channel and crop different area for the display. In combination with ZOOM, PAN and OVERLAP settings, user can crop any location of the image for each LCD, no matter it is in landscape or portrait position.
- Pay attention to image rotation limitations in input signal resolution. G408 doesn't have 90/270 image rotation function when the input is 4k/60 Hz.
- Please apply signal source before video wall setting. Otherwise the settings may be wrong.
- G408 can support interlaced signal source (i.e. 1080i). However, if user rotates or flips the image, there will be no 3D motion adaptive de-interlaced function. User may see some small flick image while the input is still image. We recommend applying progressive signal for the best video quality.
- Some media players will output maximum resolution when it is powered on each time but not follow the EDID settings in sink device. It will cause abnormal display in the video wall if this video wall has image rotation setting and the signal source resolution is more than 4k/60Hz because G408 can only support image rotation under 4k/30Hz source signal.
- Please make sure no Over-scan setting in monitor. Otherwise, the image position will be wrong.

19. Limitations in Image Flip and Rotation

Image 90/270 degrees image rotation is only available in input resolution under 4k/2k @30Hz (included). While image is rotated or flipped, there will be no 3D motion adaptive de-interlaced function. We recommend apply progressive source signal to get the best video quality.

Technical Support

20. Trouble Shooting

20.1. Front Panel LED lights

- User should see Input / Output LED lights in each channel. If no light illuminated in specific channel, please check Input / Output connecting cables, signal source & monitor in that channel.
- If user sees continuous flashing at 0.5" interval in Power LED, it means OSD may be locked. Please press [Menu] key for 5 seconds, it will disable [OSD locked] function.
- If Power key LED is flushing at 1" interval, the OSD Menu is locked and can't be used. Please use remote controller and press [850] number keys to disable OSD Menu Lock.

20.2. Intermittent or Loss of Input Signal

- Check the HDMI cable quality and make sure all cables are fitted correctly. 4k/60 signal requires high speed certified cables.
- Cable length: Connecting cable length should be short as possible. Replace a short cable to verify the possible root cause.

- **HDCP compliant issues:** If the input source or the monitors are not HDCP compliant, it is possible to stop G408 from negotiating HDCP link and show intermittent, abnormal or no image.
- **Resolution issues:** check if signal source and connecting cables can provide right signal requested by G408.
- **DVI/HDMI signal compatibility:** some display devices may only support HDMI or DVI video signal and execute wrong signal format detecting. The default output is HDMI. User can change output with DVI format through [Options]➔ [Setting]➔ [DVI]➔ [On].
- Usually, to swap with different cable, output channel, signal source and monitor can verify the root cause for the failure.
- When it is possible to have signal compatibility issue, user can add one HDMI splitter or switch in the middle to change signal impedance. It may fix the issue.

20.3. Image rotation can't be implemented

- If the input signal is above 4k/2k @30Hz, image 90/270 degrees rotation function will be disabled.

20.4. Video quality issues

- Use the highest resolution and number of color bits (RGB 4:4:4) images allowed by G408 to be used as a signal source whenever possible.
- There are a number of lower-quality AV players, the specification and actual output are difference, or because of the use of lower color sampling bits or poor image compression technology, resulting in lower quality or image is not smooth (LAG).
- If the use of H.264/H.265 compressed files, please select a player with hardware decoding to get smooth video quality.
- If the input signal is interlaced signal (interlaced-1080i), and the image is rotated or flipped, then the channel will have no [3D Motion adaptive de-interlaced] processing function. If user applies static image source, the output video will have a slight jitter phenomenon. The processing channel quality will be reduced. Use a progressive signal source setting (1080p/2160p) whenever possible.
- Please press [INFO] shortcut key to check the input/output signal settings.

20.5. System setting can't be executed:

- System control applied to complete system can only be executed through CH-1.
- After FW update, please insert small pin into RESET hole on back panel for 5 seconds to reset the system to default to eliminate unnecessary settings. It will not affect Profile Index storage data.
- After Reset, user will see "Reset to Default" message and the FW update process is finished.

20.6. Synchronization issue in the outputs

- The input refresh rate should be the same as output refresh rate so that the system can implement Frame Lock to synchronize all the outputs. If the input source is 50Hz with 60Hz output, then it is possible to see some lag among the displays.

- The display devices may have different delay time under different settings. For examples, if the system with high end video processing, such as noise reduction or ME/MC, it may increase few frame delays. Please make sure all the display with the same settings.
- Please set Options➔ Setting➔ Frame Lock as [Normal] to implement Frame Locked function while using multiple units of G408 to avoid not synchronization or frame tear issues.
- Each Processor shall be set separately.

21. **Technical support**

- User can send e-mail to support@vigillink.com together with as much information as possible.
- The following information is required for a swift response.
 - ✓ Sink device (monitor): type and model number
 - ✓ Monitor layout or specific application details (shape of video wall).
 - ✓ GeoBox model No. and series No.
 - ✓ Detailed timing of signal source and resolution.
 - ✓ Press [Info] key to get System Information and send the data to us, including input/output timing and F/W version.
 - ✓ The exact nature of the problem. Please be as detailed as possible.
 - ✓ If possible, please attach the Pictures of the issue.
 - ✓ Usually we will response with 24 hours (excluding weekends)
 - ✓ Please note that if the machine is sent back for repair, user needs to pay for some delivery cost.

22. **Safety Precaution and Maintenance**

➤ **Power Supply**

Please connect electric power for all devices in the system from the same Power Distribution Box with correct grounding. Open the power after finishing system connection to reduce the risk for system damage from high floating voltage.

➤ **Working Environment**

Please locate G408 in an environment free from dust, moisture and high temperature with good ventilation.

22.1. **Warranty:**

This device is designed and tested to the highest standards and backed by thirty-months' parts and labor warranty. Warranties are effective upon the first delivery date to the end customer and are non-transferable.

22.2. Maintenance and Repair

Apart from what is detailed in User Guide, maintenance should be carried out by competent technician assigned by VIGILLINK . If G408 is physically damaged, it should be returned for repair using VIGILLINK RMA procedures. If the unit is opened by user, it will lose the right for warranty protection.

Specifications

- ✧ Input: 2x HDMI 2.0b
- ✧ Output: 8x HDMI 1.4
- ✧ 2x HDMI 2.0b loop out port for multiple unit cascade & daisy chain connection.
- ✧ HDCP compliance: Input: HDCP V2.2/V1.4. output: HDCP V1.4
- ✧ Max. input resolution: 4096x2160 @60Hz, 7680x1200 @30Hz. 4:4:4 Chroma sampling.
- ✧ Support non-VESA STD input timings.
- ✧ 18 selectable output modes up to 2048x1200 60Hz in each independent output port.
- ✧ Selectable 8/10-bit output color depth.
- ✧ One frame latency: 16.7ms (V=60Hz)
- ✧ Support xvYCC color input processing & 8/10- bit deep color output.
- ✧ Overlap setting for edge blending in each edge up to +_ 1800 Pixels.
- ✧ 3:2/2:2 cadence, low angle smooth algorithm, high quality scaling engine.
- ✧ 3D motion adaptive de-interlace.
- ✧ 10-bit processor, frame rate conversion.
- ✧ 50Hz in/out to avoid video artifact.
- ✧ Frame lock for synchronized outputs.
- ✧ Support HDR input signal but no HDR effect in the output.
- ✧ Individual 90/180/270 rotation, flip, cropping, scaling & color adjustment in each channel.
- ✧ When image rotation at 90/270 degrees, the maximum input is 4k/2k 30 fps.
- ✧ Embedded HDMI audio in each output.
- ✧ Selectable and programmable EDID.
- ✧ ESD Protection: ±15kV (Air-gap discharge), ±8kV (Contact discharge).
- ✧ DC 12V/1.9A, max. 22.8w, (100-240 VAC PSU)
- ✧ Working environment: 45° C, 10-90% RH
- ✧ Control: IR, RS232, USB, Ethernet
- ✧ Dimensions (Body only): 330mm*162mm*58mm (without protruding parts). 330mm*173mm*69mm (including protruding part)
- ✧ Weight: 1.90 kg (body only)
- ✧ CE/FCC/RoHS Certified
- ✧ 30-Month Warranty